

SuperSlab | SuperSlab⁺

Technical Manual

REVISION | K



CONTENTS

1.0 GENERAL	3
2.0 SUPERSLAB COMPONENTS	3
2.1 Pod void formers	3
2.2 Topping slab and rib reinforcement	3
2.3 Typical Superslab layout and details	4
2.4 Concrete	4
3.0 SCOPE OF USE	5
3.1 Building types and loading suitable for the SuperSlab system	5
3.2 Ground conditions	8
3.3 Lateral resistance under wind and earthquake	10
3.4 Weights and loadings	15
4.0 INSTALLATION INFORMATION	16
4.1 Site preparation and Earthworks	16
4.2 Damp proof membrane (DPM)	16
4.3 Set out & boxing	16
4.4 Pod set out	17
4.5 Perimeter foundations	17
4.6 Internal ribs, Load bearing thickenings and Pads	17
4.7 Mesh and Topping thickness	18
4.8 Reentrant corners	18
4.9 Concrete placing, finishing and curing	18
4.10 Saw cutting (control joints) and free joints	19
4.11 Plumbing and pipe penetrations	19
4.12 Shower Rebates	20
4.13 Wing walls	20
4.14 Polished Concrete floors	20
5.0 LANDSCAPING AND ONGOING MAINTENANCE	20
5.1 Paving and landscaping heights	21
5.2 Excavation and retaining walls	21
5.3 Drainage of the site	21
5.4 Gardens, trees and shrubs	21
6.0 STANDARD DETAILING	22
6.1 Qpod substitutions detailing	26
7.0 INSULATED SLABS	32
7.1 SuperSlab+	32
7.2 QuickSet and QuickEdge	34

DISCLAIMER

This document provides design and installation information for the SuperSlab systems as per Codemark and Branz appraisal to comply with the New Zealand building code. Providing the conditions of the Codemark are adhered too rigidly, the foundation will not require specific design or a producer statements from an engineer to gain building consent. If the conditions are not able to be met, the system will require Specific Engineering Design (SED)

CHECK LIST



1.0 - GENERAL

This document outlines the specifications, construction requirements and Codemark conditions and limitations for the SuperSlab systems.

The document covers the components, site requirements, details and construction of a standard SuperSlab system. For more advice, please contact your local Allied Concrete supplier.

SuperSlab+ provides a fully insulated foundation which includes QuickSet's pre-finished insulated side wall panel and full blanket ground insulation providing a fully thermally broken slab. QuickSet's form (side wall) is pre-finished in grey with a protective wrap to be removed before building is finished.

SuperSlab+ comprises QuickSet which is made in New Zealand, with the plastic components being made from 100% NZ recycled plastics.

2.0 - SUPERSLAB COMPONENTS

The SuperSlab floor system consists of a reinforced in situ concrete perimeter footing, internal square polystyrene void formers (pods) spaced at 1200mm centers to form 100mm wide voids which are filled with concrete. Concrete is poured on top and within the 100mm wide gap between the pods (ribs) to form a 'waffle raft'. The polystyrene pods act as a formwork to minimize the concrete consumption and achieve the depth. The depth and alternate spacing of the reinforced concrete ribs create a stiff and robust foundation solution which is suitable on most soil conditions.

2.1 Pod Void Formers

SuperSlab uses 1100mm x 1100mm square and 220mm deep polystyrene pods. 1100mmx1100mm square and 300mm deep polystyrene pods can also be used where extra height is needed.

Often sites with deep topsoil or flood risks require compacted hard fill or certified fill to build up the site to achieve the required finished ground level. Adopting a SuperSlab system can save you time and cost. A deeper pod can be selected to reduce the cost of fill as well as increasing the strength and stiffness of your foundation.

Where the geometry of the slab dictates the polystyrene pods to be smaller than 1100mm x 1100mm these can be easily cut on site to fit. The 100mm internal rib and perimeter footing width (300mm) need to be maintained at all times.

Qpod's can be used with SuperSlab systems as a greener alternative to polystyrene pods. Qpod

is a recycled plastic dome system which clips together to form a 1100mmx1100mm and 220 deep void former which can be substituted for the polystyrene pods. Refer to section 6.1 for the alternative detailing using the Qpod void fillers.

2.2 Topping Slab and Rib Reinforcement

SuperSlab requires 85mm (minimum) and 100mm (maximum) thick topping slab as outlined in section 4.7. The topping slab shall be reinforced with ductile steel mesh (SE62 - minimum weight of 2.29kg/m²). The mesh must comply with the minimum requirements of the New Zealand Building Code. The mesh is to have a tensile strength of 500 MPa and needs to be ductile, achieving 10% elongation when tested to NZS4671 and the building code testing requirements. As an alternative topping reinforcement, SE62 mesh can be substituted with 10mm diameter, grade 300, class E reinforcing bars placed at 300 centers each way. Loose bars shall be chaired and tied as per NZS3109, cover shall be as outlined per section 4.7.

The 100mm wide ribs are reinforced with 12mm diameter steel reinforcing rods grade 500, class E (HD12 seismic grade). These HD12 bars are located at the bottom of the ribs with 50mm minimum bottom cover and extending across the slab in two orthogonal directions. HD12 "hockey stick" bars are located in the top of the ribs. The hockey stick bars are tied to the underside of the mesh at the top of ribs intersecting at right angles to the perimeter footing. These bars are 1350mm long and have a 150mm hook to anchor the perimeter footing to the floor slab.

Perimeter reinforcement typically consists of 2 x HD12 bottom bars and a single HD12 top bar. Additional perimeter or rib reinforcement can also be adopted for specific design cases to accommodate higher loads or spanning capabilities such as: expansive soils, liquefiable soils or piled foundations. These cases are outside the scope of this document and require specific engineering design.

Bar chairs and spacers are used to ensure the correct cover to all the reinforcement and to keep the pods in place while the slab is poured.

Qpod



Polystyrene Pod

2.3 Typical SuperSlab layout and details

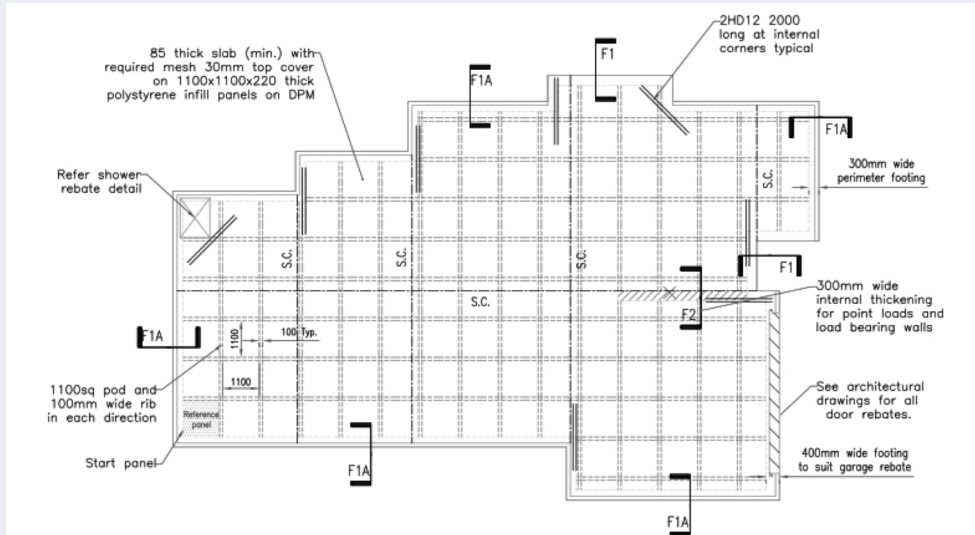

FIGURE 1 – SuperSlab layout (slab area = 197 m²)

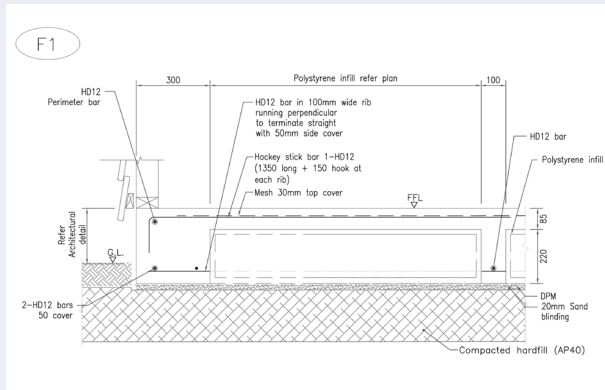

FIGURE 2 – Light clad perimeter footing detail

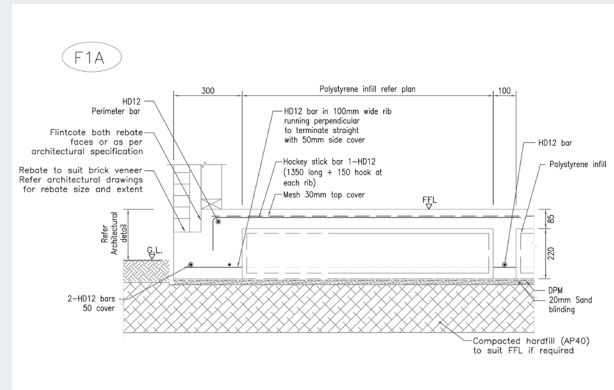

FIGURE 3 – Brick clad perimeter footing detail

2.4 Concrete

SuperSlab mixes shall be used for all SuperSlab systems. The strength of the concrete is dependent on the exposure category of the proposed foundation.

Sites located near coastal areas may be subject to windblown sea salt deposits resulting in a greater risk of corrosion. As such a higher concrete strength is required to satisfy the NZBC durability requirements of the foundation. NZS3604 clause 4.2.3.3 defines such areas as Zone D (all outer islands and coastal areas within 500m from the sea or within 100m from tidal estuaries and sheltered inlets). Foundations proposed in Zone D are to be 25 MPa minimum. For sites located away from corrosive environments (greater than 500m from the sea – Zone B or C) 20 MPa concrete can be used. The designer shall select one of the appropriate concrete mixes as per the following:

- Mix code 252CSS is used for 25 MPa applications for foundations within 500m to

the sea or 100m to fresh water.

- Mix code 202CSS is used for 20 MPa applications for foundations beyond sea spray and corrosive environments.

Note: foundations located in tidal splash zones within 50m of the beach frontage may require higher strength concrete and are subject to specific advice. So too are contaminated sites or soils within 500m of geothermal bores, mud pools, steam vents or other such sources which pose a chemical or corrosive environments. Such conditions are beyond the scope of this document.

The builder and designer shall also discuss the desired finish and the placement method with the Allied Concrete when ordering the concrete to ensure the best mix for the specific application can be delivered.

3.0 - SCOPE OF USE

Designers need to understand and adhere to the conditions and limitations as outlined below. If in doubt, please check with Allied Concrete for advice on your SuperSlab project.

3.1 Building types and loading suitable for SuperSlab Systems

SuperSlab systems has been designed to support timber framed residential houses generally satisfying the requirements of NZS3604 and as detailed below. The verification of the compliance of the design with this document is the responsibility of the designer and shall be confirmed by the building control authority issuing the building consent. Items 1-6 shall be verified by the designer. Refer to check list procedure in section 7 for further guidance.

- 1. SOIL CONDITIONS** - Buildings founded on 'good ground' as defined by the New Zealand Building Code (B1) and NZS3604. This is summarised in section 3.2 below
- 2. BUILDING TYPE** - Importance level 1 and 2 structures as per NZS1170 and NZS3604 - Standard residential house
- 3. HOUSE SIZE** - No more than two storey timber framed buildings with max height of 10m (to apex). Maximum length of 30m unless detailed with free joints in accordance with this manual as per figure

21 and 33. The foundation needs to be a regular shape with a minimum area (m²) to perimeter (m) ratio of 1. Irregular shaped foundations need specific engineering input and are beyond the scope of this document. Refer Table 2 below for guidance on shape requirements.

- 4. WEIGHTS** - Permanent (gravity) and imposed (live) loads as defined in section 3.4 - The foundation system is designed to accommodate a standard residential house generally as defined in NZS3604:2011 and defined in section 3.4
- 5. MAXIMUM SPAN AND HEIGHTS** - Maximum Roof span of 12m, first floor joist span of 5m, and maximum storey height of 3m (Cladding combinations as per table 1 and building types A-E)
- 6. WIND AND SEISMIC LOADING** - Maximum wind loading of Extra High as per NZS3604:2011 and maximum seismic hazard factor (Z) of 0.45 and soil classes A-E as per NZS1170. Also, refer section 3.4

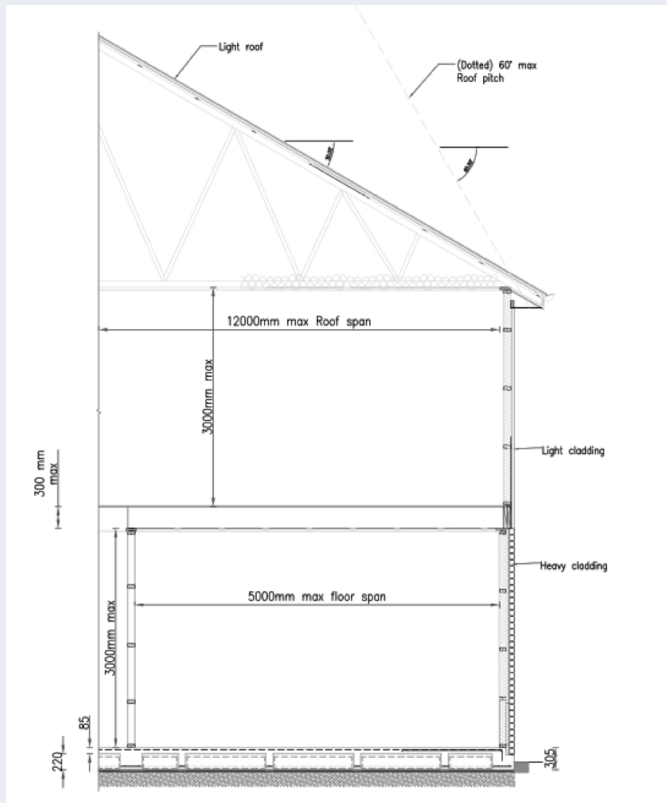

FIGURE 4 - Typical house layout

Table 1

Building type	Number of levels ¹	Level 1 Wall cladding ²	Upper storey cladding	Roof Type ³	Minimum bearing capacities and penetrometer blows ⁴	Within scope of this document
A	Single	Light	–	Light	150 kPa	Yes
B	Single	Heavy	–	Light	200 kPa	Yes
C	Single	Heavy	–	Heavy	200 kPa	Yes
D	Two Storey	Light	Light	Light	200 kPa	Yes
E	Two Storey	Heavy	Light	Light	300 kPa	Yes
F	Two Storey	Heavy	Light	Heavy	300 kPa	No, Specific Design
G	Two Storey	Heavy	Heavy	Heavy	300 kPa	No, Specific Design

Notes as referenced in table 1 above

- Two Storey external wall supporting a timber floor with maximum floor joist span of 5.0m.
- Maximum brick wall cladding height of 3.0m to lower level of two-storey building. 4.5m on a single storey building.
- External wall supporting a maximum 12m clear span of roof trusses.
- The designer shall confirm minimum bearing capacities as required for building type as per table 1. The building platform is to have consistent bearing capacity across the house floor plan. Specific design or geotechnical input is required if bearing capacities vary significantly across the building platform. Penetrometer testing and soil investigations are to be completed as per NZS4402, NZBC (B1) and NZS3604. If the designer adopts a less conservative testing criteria to determine the bearing capacity from penetrometer testing such as Stockwell 1977 or MBIE guidance document for repairing and rebuilding houses affected by the Canterbury earthquakes (section A 3.4.1), they shall be suitably qualified to interpret the “index” bearing strengths as described in the document. Suitably qualified as defined in the MBIE document includes soil technicians or other suitably trained and supervised people. Refer table 2 for penetrometer blow count criteria. Cohesive soils could also be tested using shear vanes as penetrometer testing often underestimates the strength of cohesive soils. A geotechnical engineer can provide the bearing strength to be adopted in

the design. Generally, the geotechnical ultimate bearing strength can be taken as 5 times the undrained shear strength of the cohesive soil. E.g. Undrained shear (Su) = 60 kPa would equate to 300 kPa geotechnical ultimate bearing or 100 kPa allowable bearing – “good bearing” as per NZS3604.

Buildings deviating from the limitations listed are outside the scope of this document. However, an economical SuperSlab solution can still be adopted with specific engineering design. Contact Allied Concrete for further information and advice.

Table 2

NZS3604/B1 penetrometer testing criteria for Geotechnical ultimate bearing	Number of blows per 100mm - upper 600mm subgrade	Number of blows per 100mm - below 600mm subgrade
300 kPa (good ground)	5	3
200 kPa	3.33	2
150 kPa	2.5	1.5
MBIE/Stockwell penetrometer Criteria testing criteria for Geotechnical ultimate bearing	Number of blows per 100mm - upper 600mm subgrade	Number of blows per 100mm - below 600mm subgrade
300 kPa	3	3
200 kPa	2	2
150 kPa	1.5	1.5

Foundations shape requirements

Two foundations connected by a narrow corridor will require specific engineering design (SED) and appropriate free joint detailing. Narrow corridors can be defined as a width less than 50% of the width of the smaller of the adjacent slab (W) areas as per example below. Foundations of this layout are beyond the scope of this document.

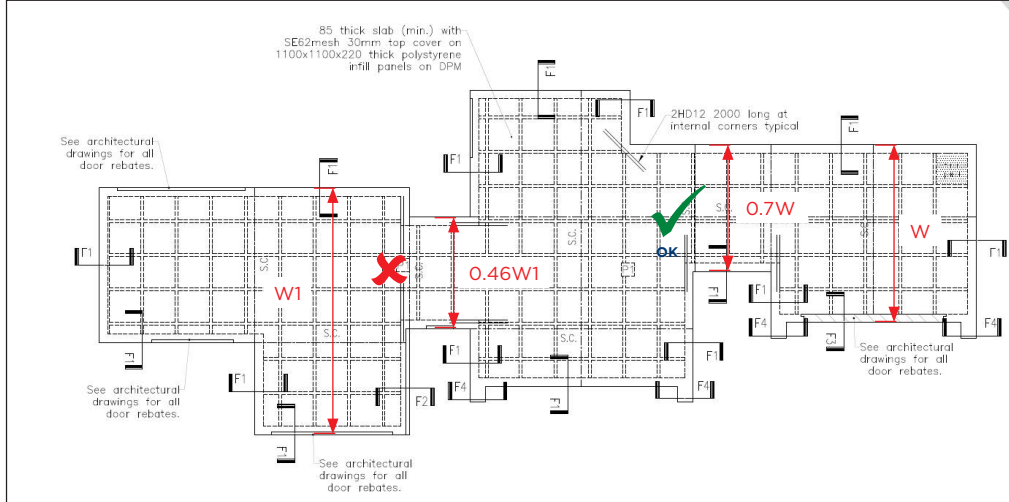

Projections which extend out from the slab by H need to be maintain a minimum width of 0.5H to fall within the scope of this manual. Projections smaller than 6m² need not comply with this requirement

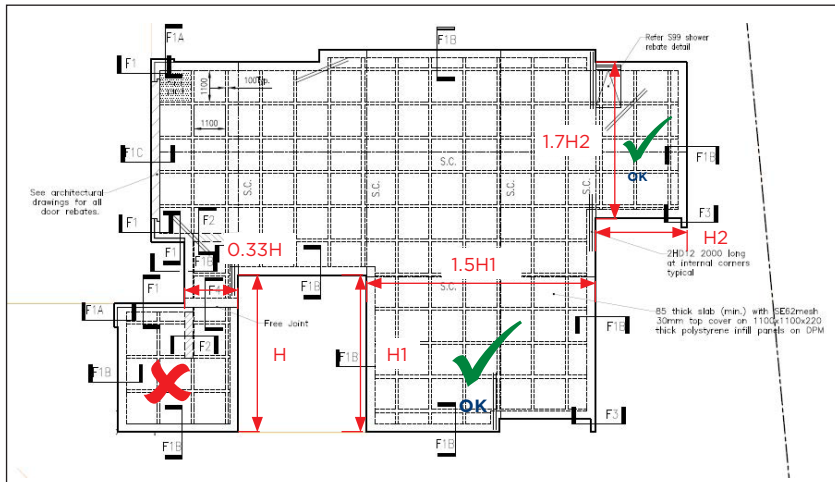

Projections are permitted providing they are regular and a minimum area to perimeter ratio of 1 is maintained for the foundation has a whole. Detailing of control joints (saw cuts) and re-entrant corners is important to minimize the risk of shrinkage cracking for buildings with projections.

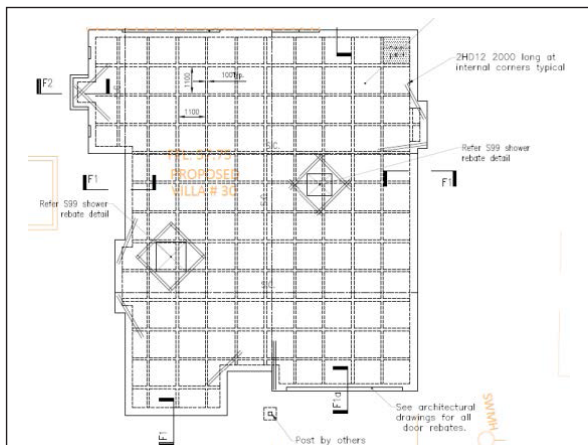

3.2 Ground conditions

SuperSlab systems have been developed for 'good ground' in accordance with NZS3604 (and the definition from the New Zealand Building Code B1) with custom bearing requirements as per Table 1 for the different building types A-E.

The New Zealand Building Code places the responsibility on the designer to confirm the soil conditions or to nominate a representative to undertake site verification of the of the soil conditions prior to construction. Refer B1/VM4 - 2.0.8. The conditions of SuperSlab require confirmation of "good ground" by the designer and local building authority prior to construction. The designer shall discuss with the local building authority and obtain their geotechnical reporting requirements for the building consent process. Often local building authorities will have hazard maps for liquefaction, expansive soils, instability and low bearing strengths that can be utilized to aid the designer with establishing "good ground". It is highly recommended the designer obtain a project specific geotechnical report prior

to building consent to establish the site soil conditions and confirm the site is suitable for a SuperSlab.

"Good ground" is defined by NZS3604 and items 1-4:

1. Consistent bearing capacities of the building platform and underlying soils as per NZS3604 and per Table 1 for given building types A-E.
2. Stable platform, free from any instability or settlement from any scenario where vertical movement greater than 25mm over the 50-year design life is expected. Refer NZS3604 - site requirements for further information.
3. Slightly expansive soils, with a maximum characteristic movement (Ys) of 20mm as per AS2870.
4. Filled platform - Confirm Items 1-3 on the cut platform. Imported fill (well graded compacted hard fill or suitable fill material approved by a geotechnical engineer) less than 600mm deep placed as per NZS4431 and NZS3604. Cut and fill batters to be completed in accordance with NZS3604 and figure 5 and 6.

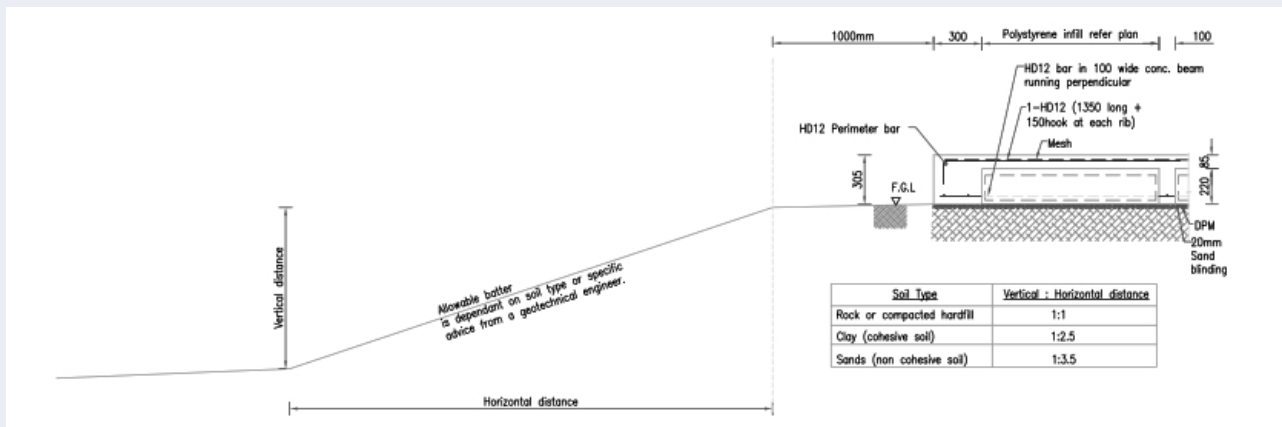

FIGURE 5 – Safe batters for raised building platform

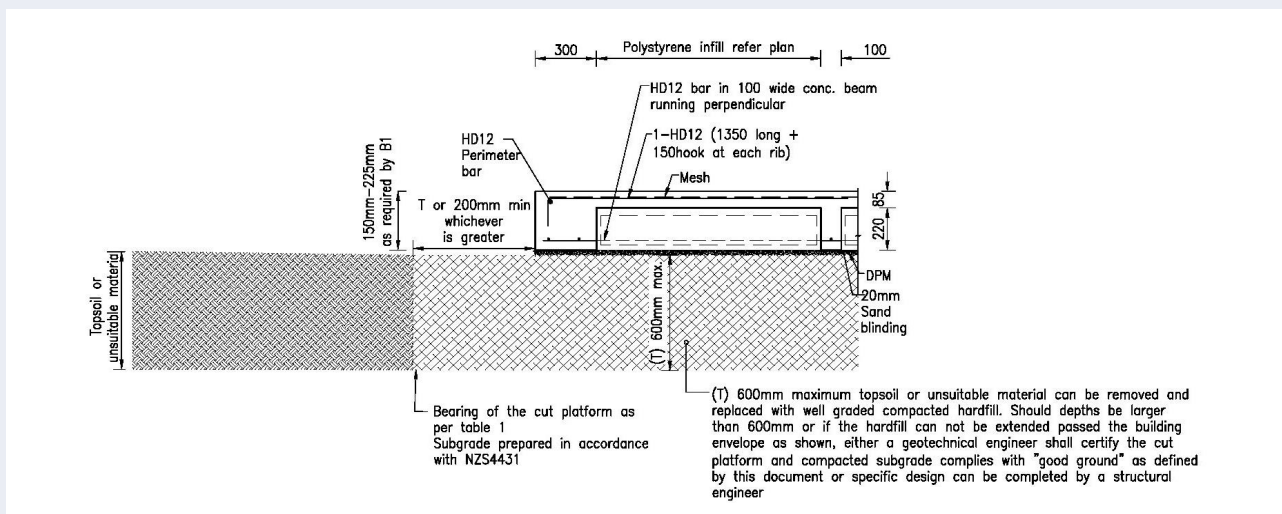

FIGURE 6 – Deep top soil subgrade limitations (Updated)

The following are conditions excluded from the definition of “good ground” and are beyond the scope of the SuperSlab Technical Manual.

5. EXPANSIVE SOILS – Cohesive clays may be prone to drying out and shrinking or expanding and heaving with seasonal moisture changes. Clay or cohesive soil with liquid limits of more than 50% or linear shrinkage of more than 15% as per NZS4402 (test 2.2 & 2.6) shall be classified as expansive soil, prone to seasonal shrink swell movement. Any movement greater than 25mm is beyond the scope of NZS3604 and the definition of good ground. For example, class M (moderately expansive, $Y_s = 40\text{mm}$) or class H1/H2 (Highly expansive, $Y_s = 60, 75\text{mm}$). The soil class as per B1 NZBC shall be determined before building on any cohesive soils.

6. TOPSOIL AND PEAT - Construction on organic topsoil or buried organic material (peat). Peat and any organic material can be prone to decay and settlement over time and when loaded. Buried top soil is common in swampy areas or sites with uncertified fill such as landfills or re-contoured sites (Uncertified earthworks).

7. BUILDING PLATFORM AND BEARING STRENGTH - Soft or weak soils with bearing strengths below 50-67 kPa allowable bearing as required for given building type as per table 1. Soil can be soft for a number of reasons however the most common reason is due to poor compaction and consolidation. Fluctuating ground water can also cause soils to lose bearing strengths. Consistent bearing capacity across the building platform is also very important. If there is significant variability of the bearing strength across the building platform this can result in differential settlement which needs to be considered with specific engineering design of the foundations.

8. SITE INSTABILITY - whether global or local.

- Construction within “close proximity” (1:2, vertical to horizontal) of any retaining walls, existing or proposed
- Construction on sites within slopes steeper than 5 degrees and as defined by NZS3604. If there are any signs or historical instability a full investigation by a chartered geotechnical engineer is required to determine the conditions and recommend foundation design parameters

9. UNCERTIFIED FILL AND BRIDGING.

Construction on any uncertified fill of any depth is prohibited. Uncertified fill can be defined as disturbed soil which has not been placed and properly compacted and as such is prone to settle under self or imposed load. Construction near any buried services, detention tanks or soakage trenches also requires specific design. Construction above or near services or soakage trenches can often encounter uncertified trench back fill or ground that is unstable. Where public services are identified near the foundations, the local building authorities shall be consulted as there are often minimum design standards required to protect their assets. If piling and bridging is required, piling parameters shall be provided in the geotechnical report and will need to be designed by a structural engineer and are beyond the scope of this document.

10. LIQUEFACTION - Construction on sites with liquefaction risks (resulting in settlement beyond B1 limits as defined in item 2 above). Loose sand and silts soils (non-cohesive) in combination with high ground water. Sites with significant risk are usually located around river deltas or reclaimed land with extensive silt and or sand deposits. Most local councils have hazard risk maps to aid in identifying these sites as Liquefiable soils are excluded by the building code

NOTE:

Foundations constructed or proposed on sites with any of the above soil conditions (items 5-10) may still be accommodated by a SuperSlab system however will require specific engineering design from a structural engineer. The structural engineer will most likely require design parameters covering the items 1-10 and these shall be addressed by a geotechnical engineer carrying out the investigation. A geotechnical engineer is able to certify ground improvements (cut and fill) to confirm the building platform achieves “good ground” and satisfies the requirements of this manual to allow the designer to proceed with an SuperSlab system. It is recommended the designer obtain a statement and inspection schedule from a chartered geotechnical engineer confirming the conditions of this manual are achieved by their subgrade design which shall be submitted to the building consent authority.

3.3 Lateral resistance under wind and earthquake

Lateral resistance to sliding under wind or seismic actions is generally resisted by friction between the slab and the ground surface. Seismic action generally governs the design for sliding rather than wind loading.

SuperSlab systems have been designed for seismic loading allowing for a maximum hazard factor of 0.45 and class E soils as per NZS1170. Refer figure 7 and 8 below for seismic hazard map of New Zealand.

The design criteria set by NZS1170.5 allows for a serviceability limit state earthquake (SLS) and an ultimate limit state earthquake (ULS). The severity, probability and required performance for these two events are very different.

A SLS event is a relatively small earthquake which has a higher probability of occurring over the design life of the building (50 years). As such the required performance of the foundation is to withstand the earthquake with no structural damage and minimal cosmetic damage. The building is to remain useable following the earthquake. The frictional resistance provided by the slab against the ground will be sufficient to resist that SLS sliding force of the earthquake. Any movement is very unlikely in an SLS event.

An ULS event is a large earthquake which has a lower probability of occurring over the design life of the building. Given the lower probability of such an event the required performance is to preserve life safety. Structural and major cosmetic damage is expected. In higher seismic areas with Z factors of 0.15 and above, it is likely the acceleration of the earthquake will be large enough to overcome the frictional resistance provided by slab against the ground surface. Thus, the slab would be expected to slide. The foundation is designed to withstand the sliding forces generated (based on a co-efficient of friction of 0.6).

Protection of services (refer figures 9, 10,11 &12)

Following the Canterbury earthquakes MBIE released a guidance document that recommends specific detailing of the plumbing services either within the foundation depth or beneath the slab. Both options require flexible connections outside the building perimeter and flexible lagging around the pipe where the pipes penetrate up through the slab. This is to avoid critical damage to the services under the slab in the event of an ULS earthquake. There is no requirement for this detail, as major structural and cosmetic damage is permitted in a large earthquake, however the services are a critical element in maintaining the economical repair of the house following a large earthquake.

SuperSlab systems require all plumbing pipes to be installed as per Figure 9 for any sites with Z factors larger than 0.15. It is also recommended that the pipe penetration details are adopted on all other foundations.

Shear Keys (refer Figures 13 &14)

An alternate option which is more robust would be install shear keys. Shear keys consist of drilled piles (900mm deep) and are spread around the perimeter of the slab. These piles are designed to lock the slab into the ground and prevent the foundation from sliding. The number of shear keys required is dependent on the seismic zone, building type and the area of the floor slab. Shear keys are not to be used in areas where there is a risk of lateral spreading from liquefiable soils. If shear keys are desired they shall be specifically designed and are outside the scope of this document.

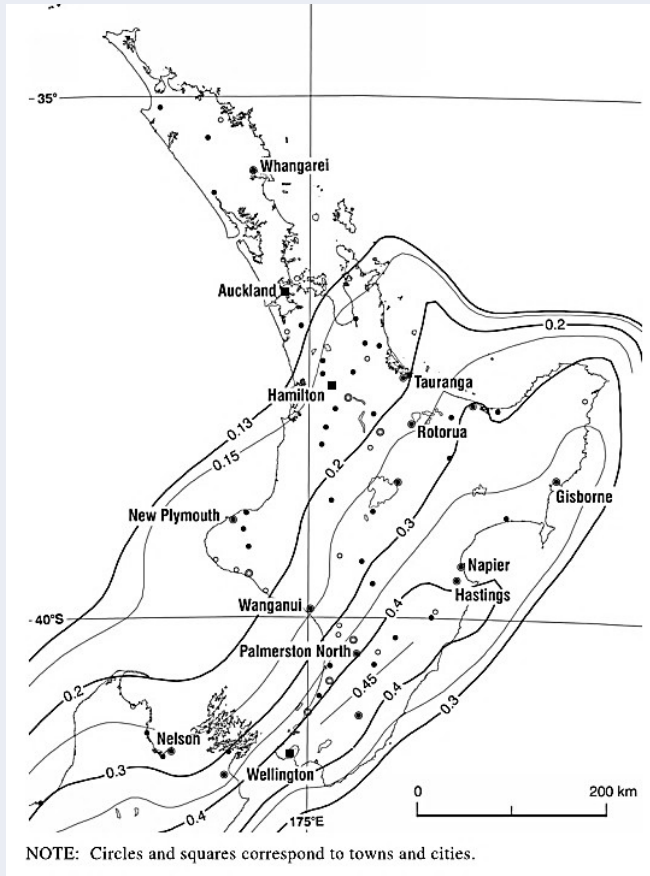

FIGURE 7 - Seismic hazard factors North Island © Standards NZ NZS1170

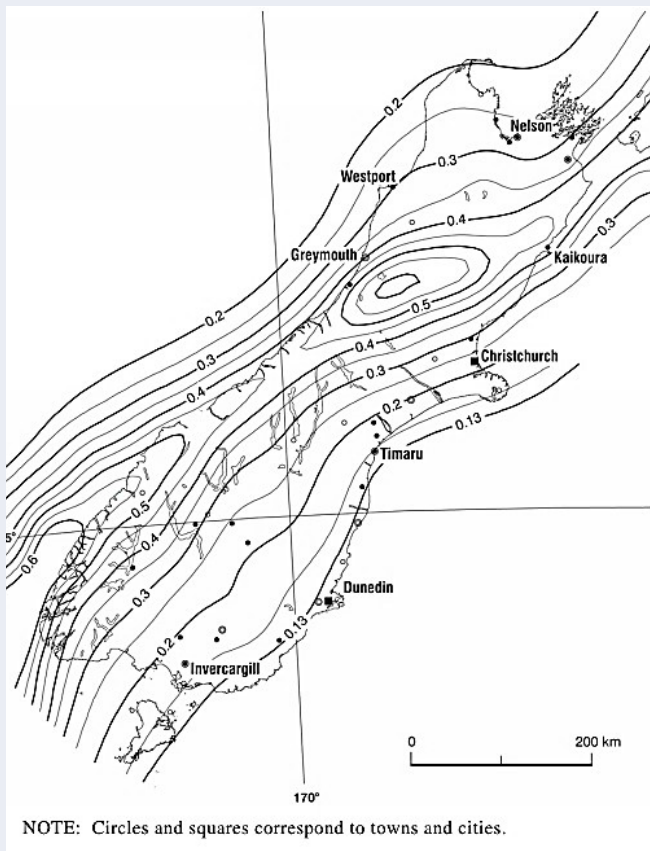

FIGURE 8 - Seismic hazard factors South Island © Standards NZ NZS1170

Pipe Penetration Details For High Seismic Zones
Refer to MBIE Guidelines Section A figure S14 & S15 and building code clause G13

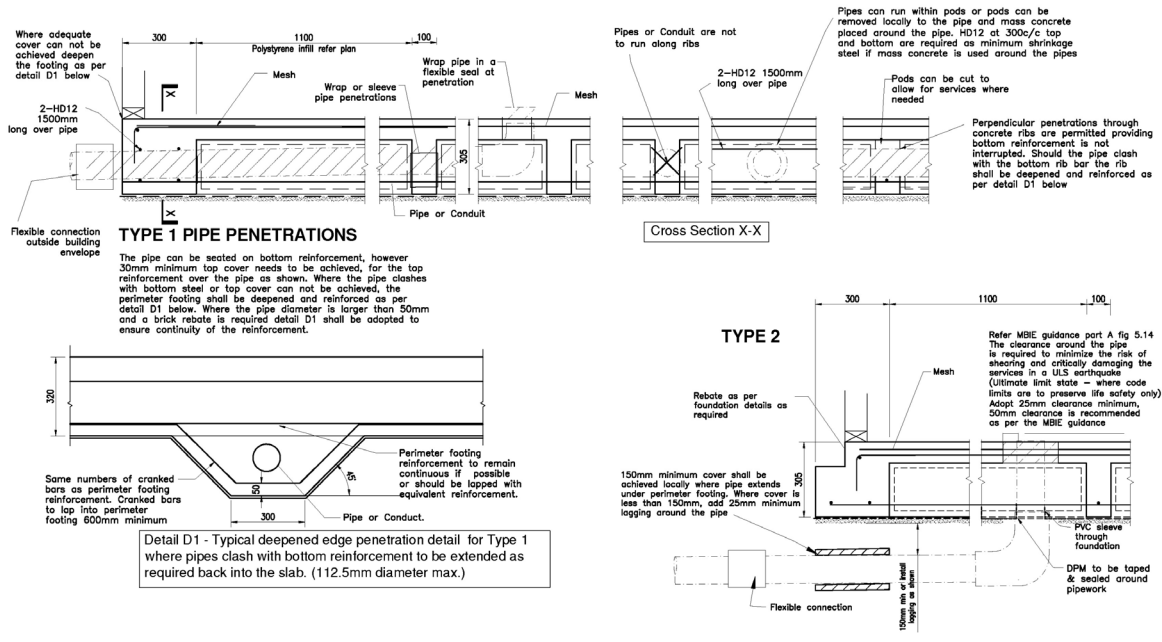

FIGURE 9 - Pipe penetration details

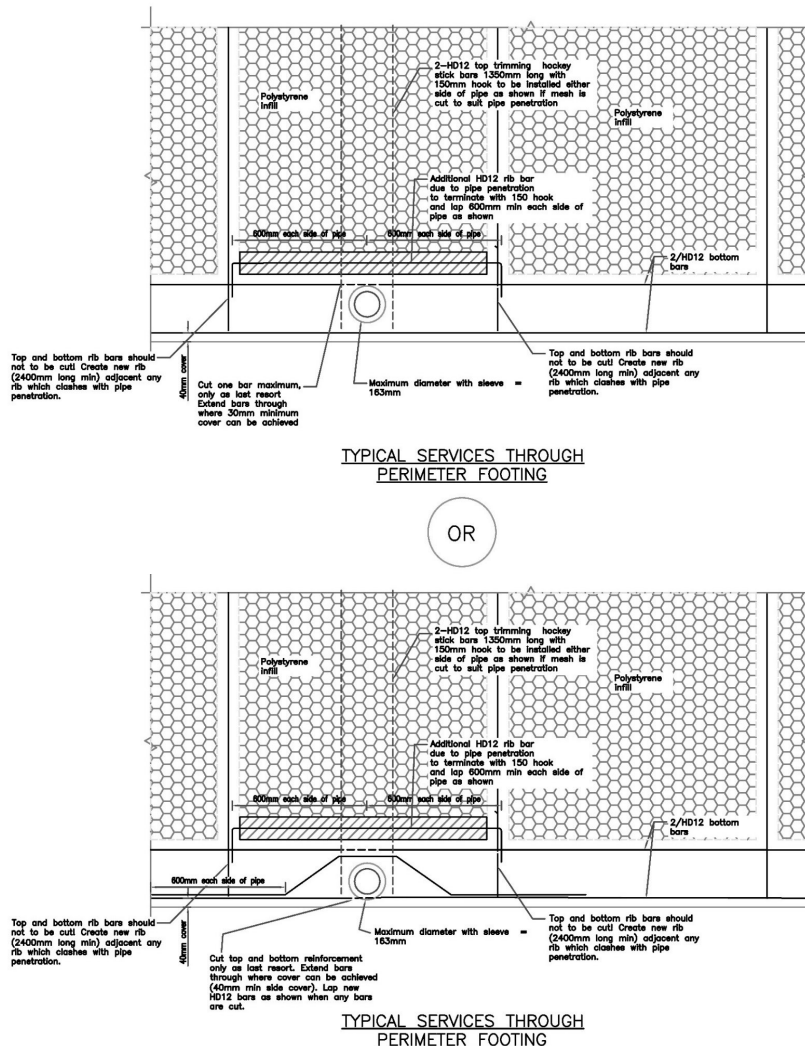

FIGURE 10 - Pipe penetration in perimeter footing

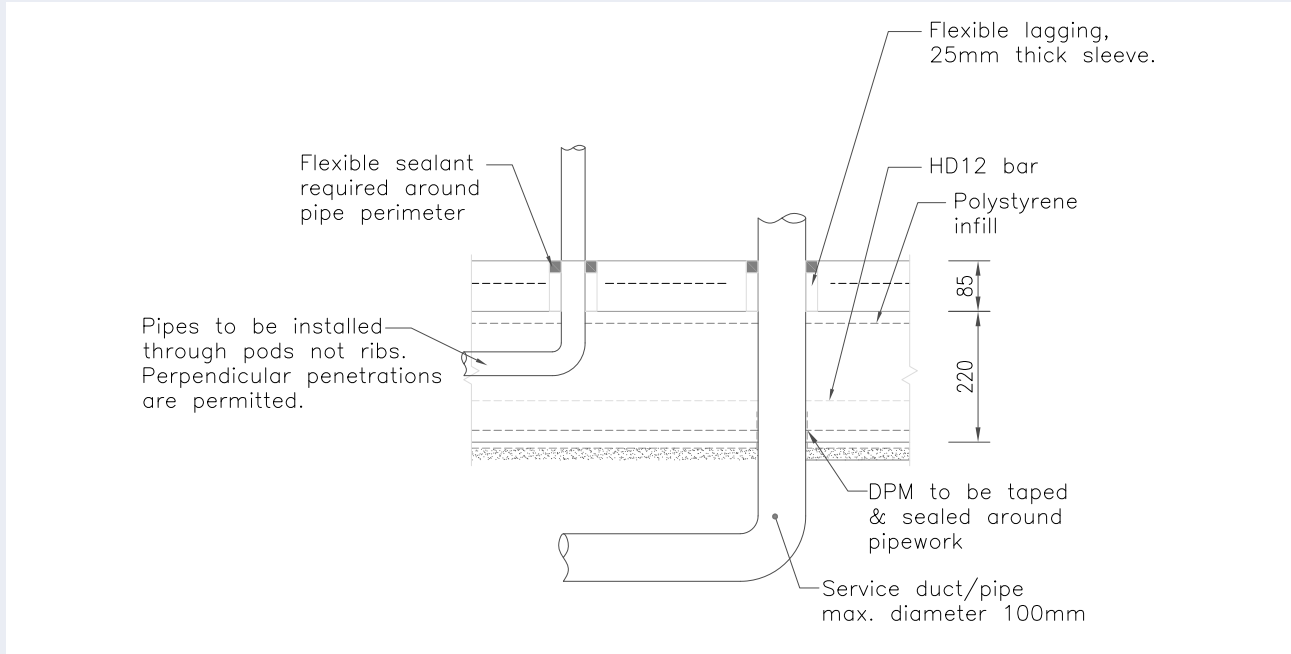

FIGURE 11 - vertical penetrations

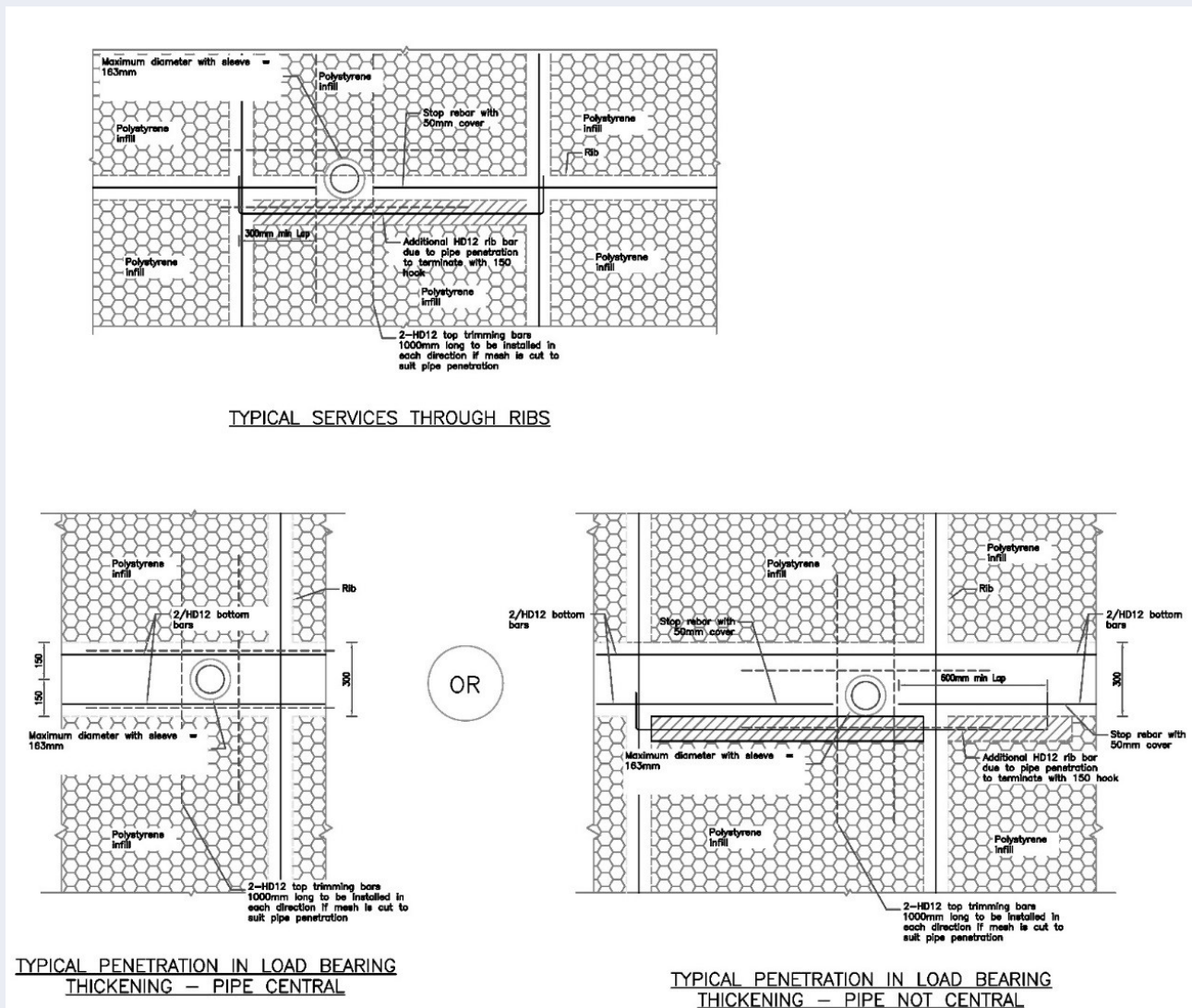

FIGURE 12 - vertical penetration through external footing or rib

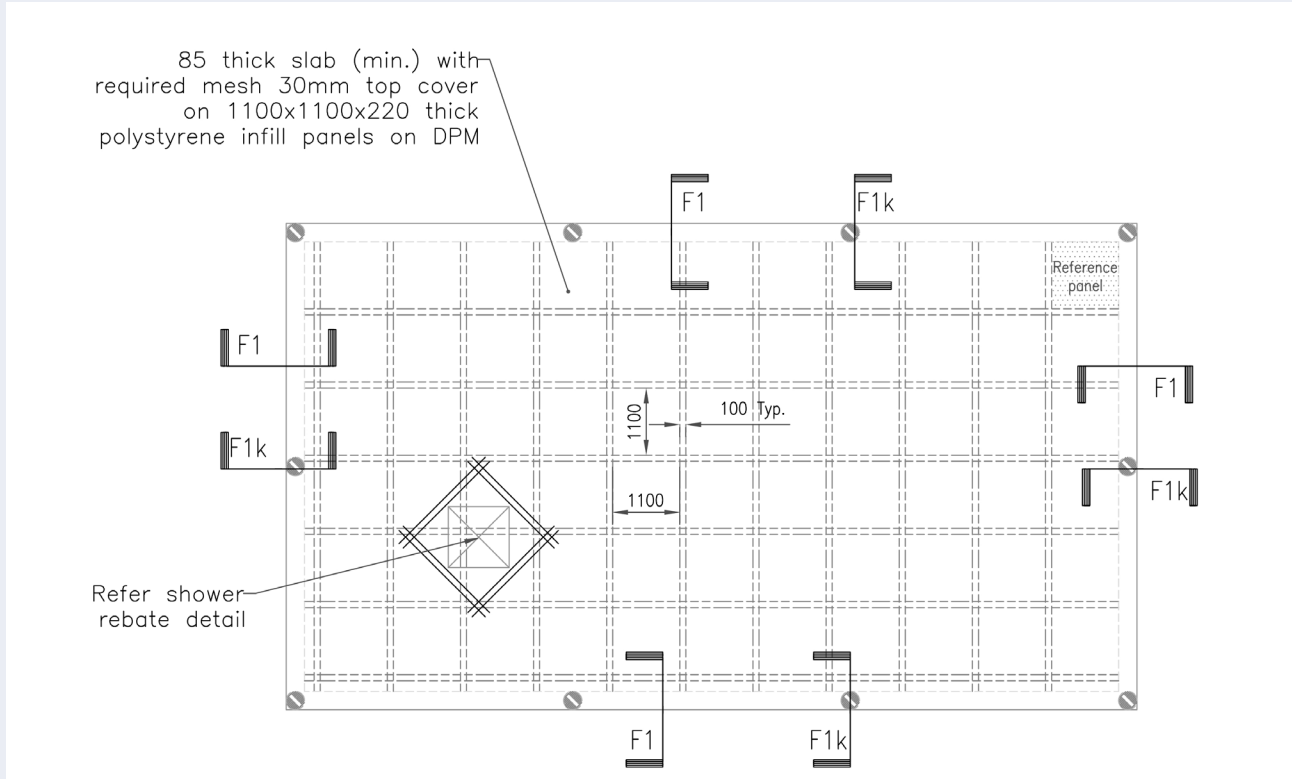

FIGURE 13 - Shear key layout

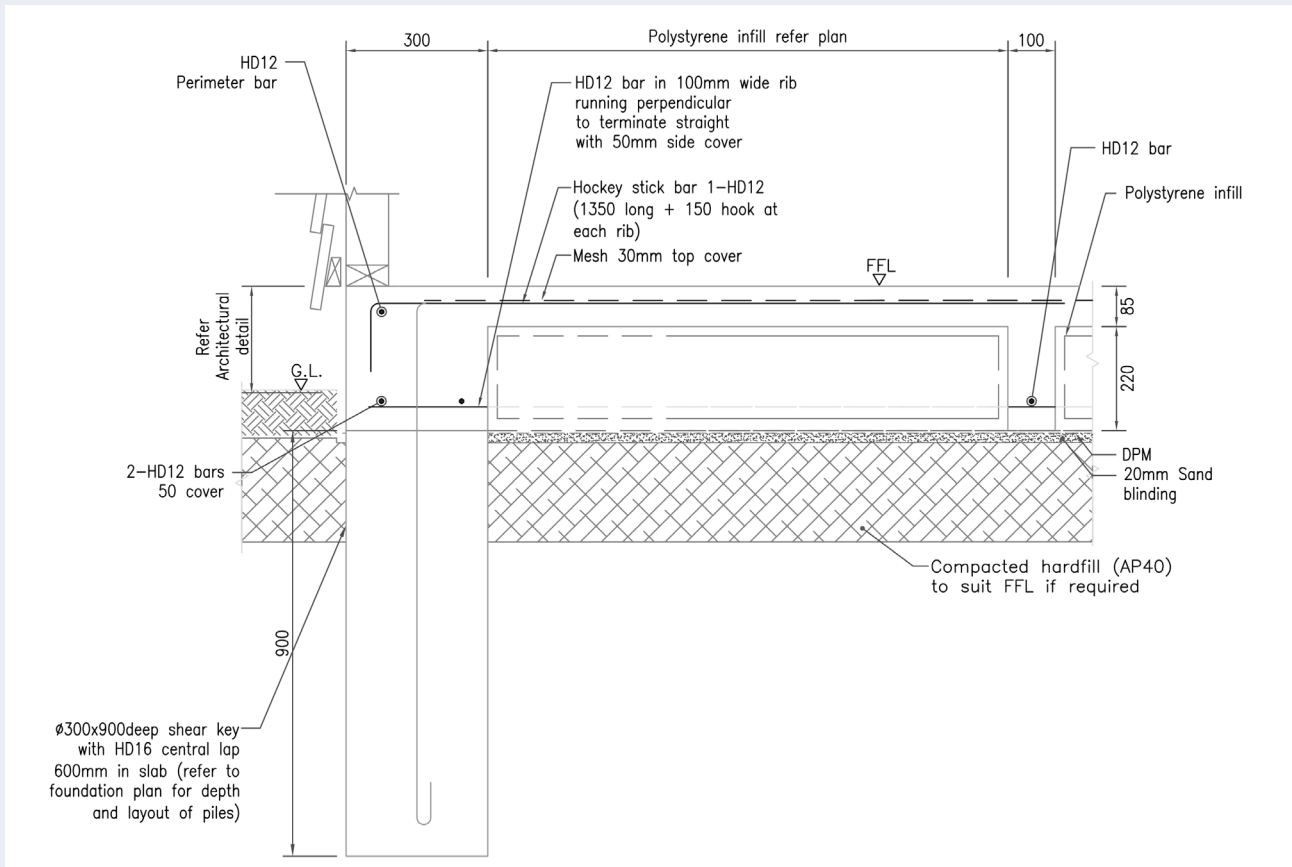

FIGURE 14 - Typical shear key detail

3.4 Weights and loadings

SuperSlab systems allows for standard residential and garage loading as per NZS3604, NZS1170 and maximum loading as per the below.

Dead or permanent loads

- Heavy roof loading 1.0 kPa - including cladding, roof framing, insulation and ceiling
- Light roof loading 0.5 kPa - including cladding, roof framing, insulation and ceiling
- First floor (timber) – 0.6 kPa - Including joists, nogs and services, flooring and lower level ceiling
- Lower level heavy cladding - 2.2 kPa (220 kg/m²)
- Upper/lower level light cladding - 0.6 kPa (60 kg/m²)

Live or imposed loading

- First floor loading 2 kPa
- Slab loading 3 kPa with 2.7 kN point load
- Slab loading of 2.5 kPa with 13 kN point load applied over an area of 300mm x 300mm
- Max vehicle weight of 25 kN or 2500 kg
- Max Snow loading as per sections 15 of NZS3604 - (2kPa, refer figure 15.1 of NZS3604)

Load bearing walls and point loading from beams, lintels and girder trusses.

Where line loads from load bearing walls exceed 10kN/m, internal thickenings shall be installed as per figure 18. Where thickenings are used the designer shall also confirm loadings do not exceed limitations as defined in 3.1 and 3.4 above.

Internal point loads (larger than 13kN) from posts or studs supporting beams, lintels or girder trusses will require a pad or thickening (1.2m long minimum and 300mm wide, located centrally to the load) as per figure 19. Point loading shall not exceed 30kN (ultimate limit state, 1.2G+1.5Q). Larger point loads are beyond the scope of this document however could be detailed by specific design such as by the truss designer.

Point loading on the perimeter footing exceeding 20kN shall require a pad as per figure 20. Point loading exceeding 30kN are beyond the scope of this document.

4.0 - INSTALLATION INFORMATION

The following section outlines the standard installation details for SuperSlab systems designed in accordance with this technical literature. Nonstandard or specially designed projects may require site specific specifications. The consented drawings, NZ Building Code and current best practice shall be adhered to at all times.

If Specific engineered design (SED), all construction shall be inspected by an engineer, the council and/or an approved representative of Allied Concrete who has been specifically trained prior to pouring any concrete.

Codemark compliant SuperSlab systems must be supervised by suitably qualified LBP with relevant carpentry or foundation qualification.

All bending of bars shall be carried out in accordance with NZS 3101. Minimum bend diameters for main reinforcing bars (between 6-20mm dia.) bar shall be 5 x diameter of the bar (db) measured to the inside face of the bend.

All bar laps shall be 50 x db or greater.

4.1 Site preparation and Earthworks

All topsoil, organic material and any soft soil (below design bearing strength) shall be removed from the building platform (refer figure 6) and in accordance with the building consent specification and as per section 3.0 above. Any isolated soft spots shall be excavated to a depth where adequate bearing is achieved.

Compacted hard fill (well graded AP40) or geotechnically approved fill material may be required to achieve the finished floor levels.

It is very important to achieve adequate compaction of a filled subgrade. The earthworks contractor shall compact granular fill in 150mm maximum layers in accordance with NZS4431 and NZS3604 (section 7.5.3). Fill depths exceeding 600mm thick, will need to be certified by a geotechnical engineer to achieve a minimum of 95% compaction of the maximum dry density as determined by test 4.1.1 per NZS4402. The geotechnical engineer shall also confirm the building platform meets all the requirements of section 3.2 of this document.

Clay or cohesive fill shall be compacted to achieve the below as per NZS4431. Clay or cohesive fill shall be certified by a geotechnical engineer:

Minimum Shear Strength and Maximum Air Voids Method

AIR VOIDS PERCENTAGE

(As defined in NZS 4402)

Average value less than	8%
Maximum single value	10%

UNDRAINED SHEAR STRENGTH

(Measured by Pilcon shear vane - calibrated using NZGS 2001 method)

Average value not less than	150 kPa
Minimum single value	120 kPa

The average value shall be determined over any ten consecutive tests

The cut platform shall not be left exposed to dry out, this is particularly important in areas where expansive soils (clay soil) have been identified. Where a platform has been left exposed and there are prevalent cracks (10mm or greater) through the building platform it is important to consult with a geotechnical engineer to confirm remedial action prior to constructing the floor slab.

A clean sand blinding layer (10mm minimum, 20mm maximum) shall be installed on the cut ground level or on top of the certified subgrade layer. The blinding layer will create a level platform, reduce shrinkage forces in the floor slab and protect the DPM from being punctured by shape aggregates.

4.2 Damp proof membrane (DPM)

A continuous damp proof membrane shall be placed on top of the sand blinding layer over the entire slab area in accordance with NZS3604 section 7.5.4 – 7.5.6

Where polyethylene (polythene) sheet damp proof membrane is to be used, the material shall be not less than 0.25mm thick, have lapped joints not less than 150mm wide which are sealed with pressure sensitive plastic tape not less than 50mm wide. The DPM shall be protected from damage during construction. Refer section 4.14 for polished concrete

4.3 Set out & boxing

Site profiles, levels and positions on site shall be determined by the builder and/or surveyor. Any discrepancies in the dimensions shall be discussed with the architect as soon as possible.

Boxing of correct height and levels shall be erected around the perimeter of the slab ensuring that any boxing supports do not

penetrate the DPM layer.

All rebates whether for brickwork, garage door thresholds or joinery shall be allowed for in the boxing as per the architectural drawings.

4.4 Pod set out

The polystyrene pods shall be placed on the DPM layer within the perimeter boxing generally as per the set-out drawings provided.

Proprietary spacers can be supplied with the SuperSlab pods by Allied Concrete.

The set out of the pods shall ensure that the perimeter footing width (300mm wide) and rib width (100mm) is always maintained. The drawings and details shall be carefully checked to ensure the construction matches the consented design drawings.

Internal load bearing walls will be marked on the drawings and these also need to be accommodated in the pod set out (or cut into the pods if preferred).

A new reference point can be created providing the footing and rib thicknesses are maintained, ribs are kept continuous and all internal point loads or load bearing walls are supported.

Where pods require cutting to suit the dimensions and set out of the floor, care shall be taken to ensure that the remaining pods are no less than 200mm wide. Where narrow pods occur (less than 200mm width) then the pod shall be removed or the set out merged with an adjacent full width pod to create two narrower pods of 600-800mm wide with a standard 100mm wide rib between. Where footings or ribs are to be wider than detailed an extra HD12 bar shall be installed in the bottom of the footing or rib per 100mm increase in width.

The maximum pod size in all cases shall not exceed 1100mm x 1100mm square. Either depth of 220 or 300 deep polystyrene pods are acceptable providing they are detailed and installed in accordance with this document.

Qpods can be used as an alternative to polystyrene pods. The 1100mm x 1100mm square (maximum) void former is created by clipping four 550mm square Qpods together. Qpods can easily be omitted to allow for pipe service penetrations or pads to be installed. 100mm wide extension pods can also be clipped onto the side of the pod where the spacing is less than 550mm wide to reduce concrete consumption. Refer section 6.1 for detailing.

4.5 Perimeter foundations

The perimeter edge beam is typically 300mm

wide however larger widths could be specified when ground conditions or edge detailing of cladding dictate this in the specific design.

Typically, 2 HD12 bars (Grade 500E deformed bars) are used for bottom steel in the footing and 1 HD12 used as top reinforcement where required. The bottom bars shall be placed onto bar chairs to achieve 50mm bottom and side cover.

HD12 starter bars (Hockey stick bars) are used at 1200mm centers (or at the top of each rib). These are 1350mm long with a 150mm hook anchoring the footing to the floor slab. This is particularly important for slabs with large rebates such as brick veneer clad houses. The large rebates prevent the mesh from achieving the required anchorage into the perimeter footing. The Hockey stick bars also give the Superslab the strength it needs to tolerate up to 25mm differential settlement as defined by B1 NZBC. Hockey stick bars of varying lengths are specified in specially designed foundations depending on site conditions and levels of soil expansiveness. Hockey stick bars shall be tied underneath the mesh to ensure 30mm minimum top cover to all the reinforcement. The top HD12 longitudinal bar is tied perpendicular to the underside of the hockey stick bars. All the reinforcement shall be sufficiently chaired so that the mesh maintains 30mm top cover and all reinforcement maintains 50mm side cover.

The perimeter footing may have rebates to accommodate exterior cladding details such as bricks, garage door rebates, and full height joinery rebates. The rebates shall be coordinated and set out in accordance with the architect's drawings. The maximum permitted rebates are 150mm wide by 120mm deep or 200mm wide and 25mm deep.

4.6 Internal ribs, Load bearing thickenings & Pads

A standard internal rib is 100mm wide and has 1 HD12 bar located in the bottom of the rib with 50mm cover to the DPM.

Extra wide ribs or ribs with additional reinforcement including links (shear reinforcement) can be specified to suit site specific design requirements and where required will be detailed on the engineering drawings.

Ribs shall run from one side of the slab to another in a straight line. If an offset is created a 300mm slab thickening is required and terminating rib bars shall be anchored into the 300mm thickening with a 150mm hook and 250mm development length. HD12 rib bars shall be lapped (600mm minimum) where required. See figure 18 for the internal slab thickening detail.

Load bearing walls, internal and external point loads shall be detailed in accordance with figures 18, 19 and 20.

Proprietary 15kN hold downs for brace walls often require a 100mm minimum slab thickness to achieve the required embedment. The Designer shall either detail thickenings (figure 18) under brace walls or alternatively adopt 100mm topping (if required in the anchor specification). The designer may also seek SED of the anchors to achieve the required rating into 85mm topping.

4.7 Mesh and Topping thickness

The mesh used in the 85mm topping is SE62 (or 2.29kg/m² minimum) grade 500 E as per NZS4671 and NZBC clause B1.

The mesh shall be supported on 40mm chairs for an 85mm topping. Proprietary Castle G25/40 bar chairs are to be used or equivalent bars chairs complying to AS/NZS 2425:2015. Longitudinal rail bar chair chairs without specific testing to confirm there is no reduced performance in shear and flexural capacity of the topping slab are excluded from this document and shall not be used. The chairs shall be located on top of the polystyrene pods and be of sufficient number to ensure the mesh does not sag excessively between support points. Top covering on mesh shall be 45mm maximum and 30mm as a minimum. Qpods have bar chairs built into the pods to support mesh to the appropriate cover and have been load tested to confirm topping performance is not compromised.

Topping thickness shall be a minimum thickness of 85mm in all locations. There is no acceptable construction tolerance for the topping thickness less than 85mm especially in the garage area. Where underfloor heating or polished concrete is specified the topping shall be increased to 100mm. Bar chairs and top cover to mesh to shall be maintained as specified above. Toppings greater than 100mm thick will require increased mesh reinforcement to meet minimum shrinkage requirements of NZS3101 and will require specific engineering input and are beyond the scope of this document.

Where underfloor heating is specified, the pipes shall be no larger than 16mm diameter. It is recommended the underfloor heating pipes are installed below the mesh. This is to avoid increasing the top cover to mesh and to avoid the risk of damaging the heating pipes when saw cuts are installed. Increasing the mesh top cover would increase the risk of shrinkage cracking and as such shall be avoided.

As outlined in 4.6, 100mm topping may also be selected by the designer to comply with minimum slab thickness which are required by proprietary bracing hold downs

4.8 Reentrant corners

At re-entrant (internal) corners additional steel is required to reduce the risk of cracks propagating from the internal corner into the slab. The additional steel will be indicated on the drawings and consist of 2 HD12 bars, 2000mm long placed diagonally across the corners. Spaced 100mm apart with the first being located with 50mm side cover to the corner. Corner bars shall be installed parallel with a sawcut if there is a sawcut to be installed at the reentrant corner. Should sawcuts be installed in each orthogonal direction of the corner than diagonal bars are not required, refer figure 1.

4.9 Concrete placing, finishing and curing.

PLACING

The design documentation will specify the required mix code for each design.

It is important to explain the placement method to Allied Concrete to ensure the appropriate mix is supplied.

Only Allied Mix code 252CSS shall be used for 25 MPa applications or Mix code 202CSS used for 20 MPa applications. Refer polished concrete section below (4.14 for polished concrete mix code).

Failure to use the correct Allied concrete mix specified will breach the conditions of the Codemark and may prevent the foundation from obtaining a Code Compliance Certificate (CCC).

Concrete placing shall be carried out by experienced personnel and shall be carried out strictly in accordance with NZS3109

No water shall be added to the as delivered concrete unless approved by the design engineer within the restrictions of NZS3104 clause 2.9.3.1

Concrete shall not be placed until all reinforcement has been inspected by the engineer, council and/or an approved engineer's representative. Failure to carry out a pre-pour inspection may result in difficulties in obtaining a CCC.

Care shall be taken during the pouring process to ensure that the polystyrene pods do not move around. Ideally concrete shall be placed on top of each pod prior to infilling between

the ribs to prevent pod flotation or movement during concrete placing.

The concrete shall be placed so that its working face is generally vertical, and normal to the direction of placing. It shall be placed over the width of the slab in such a manner as to minimize segregation.

Concrete shall be thoroughly vibrated around all steel and against all boxing and formed rebates within the perimeter of the slab, as per code and best practice requirements.

Where good access exists around the site and sufficient labor is employed then the concrete can be placed directly from the truck using the chute or wheel barrows. If these methods are used it is important that the mesh reinforcement and pods are protected from wheel barrow traffic and correct covers are maintained.

Alternatively, a slump pump can be used with either 13mm or 19mm aggregate.

FINISHING

The top surface of the slab shall be screeded immediately after placing/vibration has been completed.

Screeding shall be carried out with a level as a reference to ensure the top surface is finished within tolerance.

A trowel and an edging tool shall be used to finish the slab to a U3 finish in accordance with NZS3114. The finish surface shall be blemish free with all slab edges tooled off to form a rounded edge to help prevent cracking.

CURING

Foundations shall be cured for at least 7 days in accordance with NZS3109. If this process is omitted or modified the contractor will need to take responsibility for controlling shrinkage.

When the possibility of heat, wind, rain or low humidity could induce premature drying of the top surface the contractor shall either delay the pour or take appropriate actions to mitigate plastic cracking forming in the surface of the slab. One such option is to apply an anti-evaporation agent over the concrete surface after screeding to mitigate excessive evaporation of water from the concrete surface. Additional curing measures including ponding of water on the surface of the slab, sprinkling the slab surface regularly or the use of wet sacking placed over the slab can also be adopted.

Where a large change in ambient temperature is expected during the first 24 hours such as a very cold night then continuous wet curing via ponding or sprinkling is recommended to mitigate thermal shock and cracking in the slab.

Mitigating shrinkage cracking shall also be discussed with the concrete supplier to allow for an adequate mix or concrete additives to be utilized where appropriate.

The surface finishes specified in the building consent documentation need to be achieved by the contractor. These may include colored or polished concrete. The concrete mix and curing method shall be selected to achieve the specified finish.

4.10 Saw cutting (control joints) and free joints.

Saw cut joints shall be cut into the slab within the 24 hours or as early as possible, once the slab is sufficiently hard to walk on.

Saw cuts shall be 20-25mm deep (for the standard 85mm topping). For thicker toppings deeper saw cuts will be required of approximately 1/4th of the topping thickness. Saw cuts shall be made where indicated on the drawings.

Re-entrant corners are at higher risk of cracking due to differential stresses developing in the slab with different rates of curing on the exposed edges than compared with the internal slab. Saw cuts shall be installed at re-entrant corners and at 6m x 6m (maximum) spacing or located to create squares where possible. Refer 4.14 below for polished concrete. Creating a square or regular cut patterns will aid in mitigating differential curing in the topping resulting in shrinkage cracking.

Slabs longer than 30m will require a free joint, which shall be installed as per figure 21 and 33 of this manual. It is important that top reinforcement stops either side of the sawcut and the bottom reinforcement extends perpendicular to the free joint. Should the free joint not be perpendicular to the length of the slab it will not work, and this detail will require specific design. The bottom reinforcement is to extend a minimum of 1200mm either side of the joint and be debonded as per figure 21 and 33. Cladding and floor coverings in particular which cross the free joint need to be detailed appropriately to tolerate the horizontal movement which could occur.

4.11 Plumbing and pipe penetrations

There are two options for installing the plumbing services in combination with waffle slabs. The pipes can either be installed within the subgrade beneath the pods and concrete foundation or within the depth of the waffle slab itself.

Where falls allow and for all gas or critical ducting it is recommended the pipes are installed within the depth of the floor slab (type 1) flexible lagging shall also be included

around the pipes. Installing the pipes within the depth of the slab will mitigate the risk of damage occurring underneath the floor (where it would be difficult to repair) in the event of an earthquake.

Where pipes cannot achieve the required fall, or if the diameter is too large, these can be installed within the subgrade (type 2) and penetrate up vertically through the slab. Again, a clearance around the pipe shall be maintained (25mm minimum or recommended 50mm as per the MBIE guidance).

Pipes are not permitted to run along or within ribs and footings or penetrate up through ribs and footings without special detailing. Pipes are permitted to cross perpendicular through a rib or footing providing they can achieve the required cover refer figure 9.

Standard detailing requirements are to be followed for all standard SuperSlab foundation. Detailing beyond the limitations provided are beyond the scope of this document and would require specific engineering design.

4.12 Shower Rebates

SuperSlab systems have been designed to accommodate a 50mm deep shower rebate. Refer standard details as per figure 15. All pods in contact with the shower rebate are cut down by 50mm and mesh is lowered and chaired appropriately with the correct cover and lap. Trimming bars are required around the shower as per Figure 15. It is important the reinforcement of any perimeter footings, ribs or internal slab thickenings extending across or adjacent to a shower rebate are kept continuous. The maximum area of any shower rebate for SuperSlab systems is 4m². Larger or deeper rebates can be accommodated with specific engineering design and are beyond the scope of this document.

4.13 Wing walls

Small wing wall projections are permitted providing they are detailed as per section 6 of this manual and comply with the below:

- Maximum projection or cantilever from the slab envelope is 600mm
- Single storey with light weight cladding and a maximum height of 2700mm
- No point loading from girder trusses or beams on the 600mm cantilever

Any wing walls not complying with the above are beyond the scope of this document and may require specific design or detailing to NZS3604.

4.14 Polished Concrete floors

Where a Polished aesthetic is selected it is important to take extra precautions to mitigate shrinkage cracking. It is not practical to assume any slab will be crack free however the below will mitigate the risk of shrinkage cracking:

- The mix design may be tailored for the conditions and desired finish. As such it is important to discuss the conditions with your local Allied Concrete supplier before the pour.
- Sawcuts shall be reduced to 4x4m. These shall be installed as soon as practical and no later than 24 hours
- The slab shall be cured in accordance with NZS3109. I.e., flooding the slab for 7 days
- A double layer of DPM shall be adopted
- The polisher shall check the compatibility of the surface hardener with the concrete mix supplied prior to the pour and adjust as required
- Polished mix codes for 13mm or 19mm aggregate shall be as per the below
 - » 3013GRN
 - » 3019GRND

5.0 - LANDSCAPING AND ONGOING MAINTENANCE

Foundation maintenance shall be broadly in accordance with AS2870: Appendix B. Care shall be taken on clay sites which are expansive within the limits of section 3.2, as work and planting around the slab perimeter can have a detrimental effect on the slabs performance.

5.1 Paving and landscaping heights

The level of permanent paved, concreted and landscaped surfaces shall be kept within the limits stated in NZS3604 clause 7.5 (Figure 7.11 of NZS3604)

For paved or concreted surfaces the minimum step from the internal finished floor level to the finished exterior level shall be no less than 150mm.

For grassed or permeable surfaces the minimum step from the internal finished floor level to the ground level shall be no less than 225mm.

There may be further requirements by the architect or the local building authority in flood prone areas.

5.2 Excavation and retaining walls

Excavation next to the edge of the SuperSlab system shall be avoided where possible. Under no circumstances shall excavation take place which will undermine the edge of the slab

Excavation or construction of retaining walls (lower than the slab level) within a 1:4 gradient from the underside of the slab to the base of the excavation/wall shall be avoided. A qualified engineer shall design all retaining walls within this zone to ensure that loss of vertical and lateral support (during construction or permanently) does not occur.

5.3 Drainage of the site

Sands, silts and clays shall be protected from becoming extremely wet by adequate attention to site drainage and prompt repair of plumbing leaks.

The site shall be graded or drained so that water cannot pond against or near the building. The ground immediately adjacent to the building shall be graded to a uniform fall of 50mm minimum away from the building over the first meter. The site drainage shall be maintained for the design life of the building (normally 50 years)

The development of the gardens shall not interfere with the site drainage requirements. Garden beds immediately adjacent to the slab edge or undermining the slab edge in anyway are not permitted.

5.4 Gardens, trees and shrubs

Planting of trees shall be avoided near the foundations as they can cause damage due to drying of clay and result in excessive seasonal ground movement.

To reduce, but not eliminate, the possibility of foundation damage, tree planning shall be restricted to a horizontal distance equal to that of the mature height of the tree. Where rows or groups of trees are involved the above distances may need to be increased and specific advice shall be sought. Please note that removal of mature trees from the site can also cause issues with ground movement.

6.0 - STANDARD DETAILING

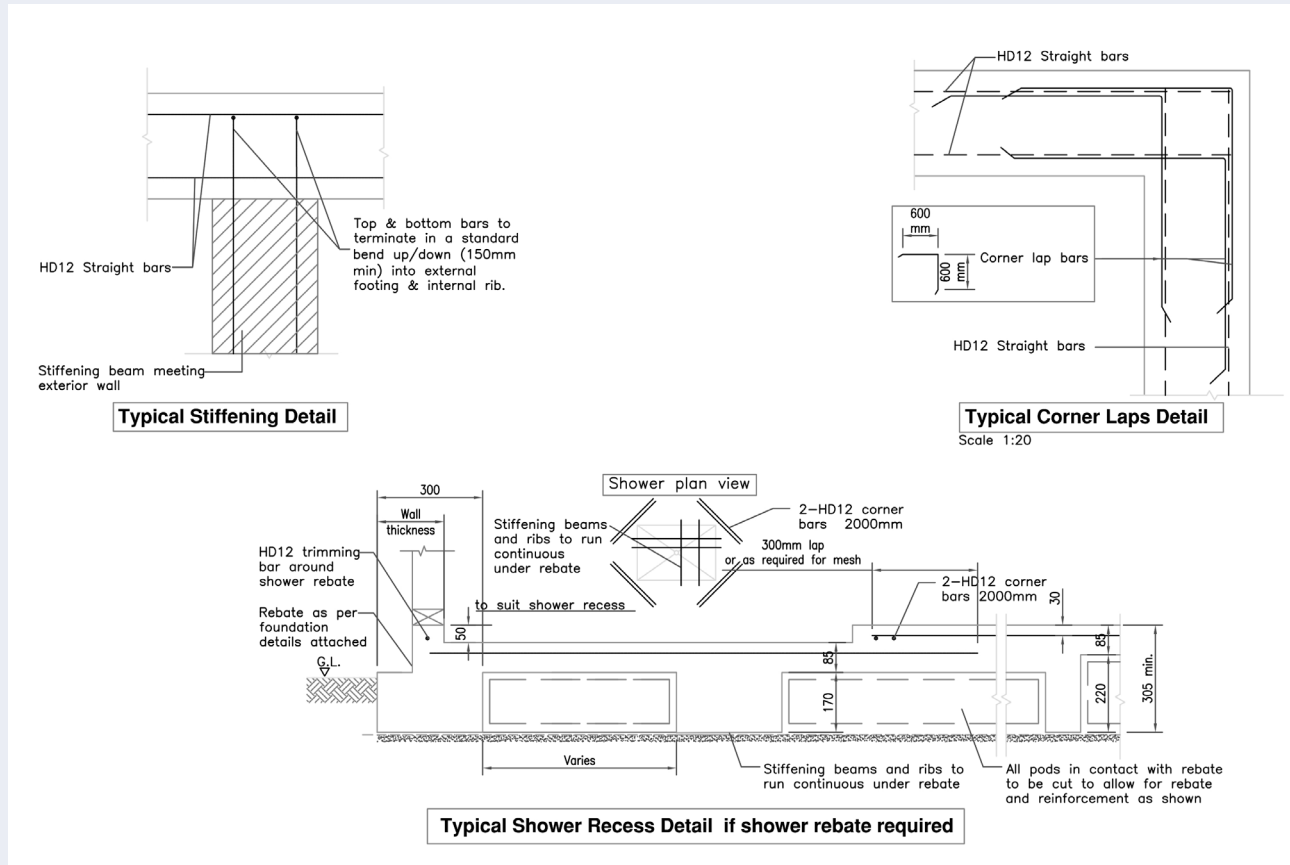
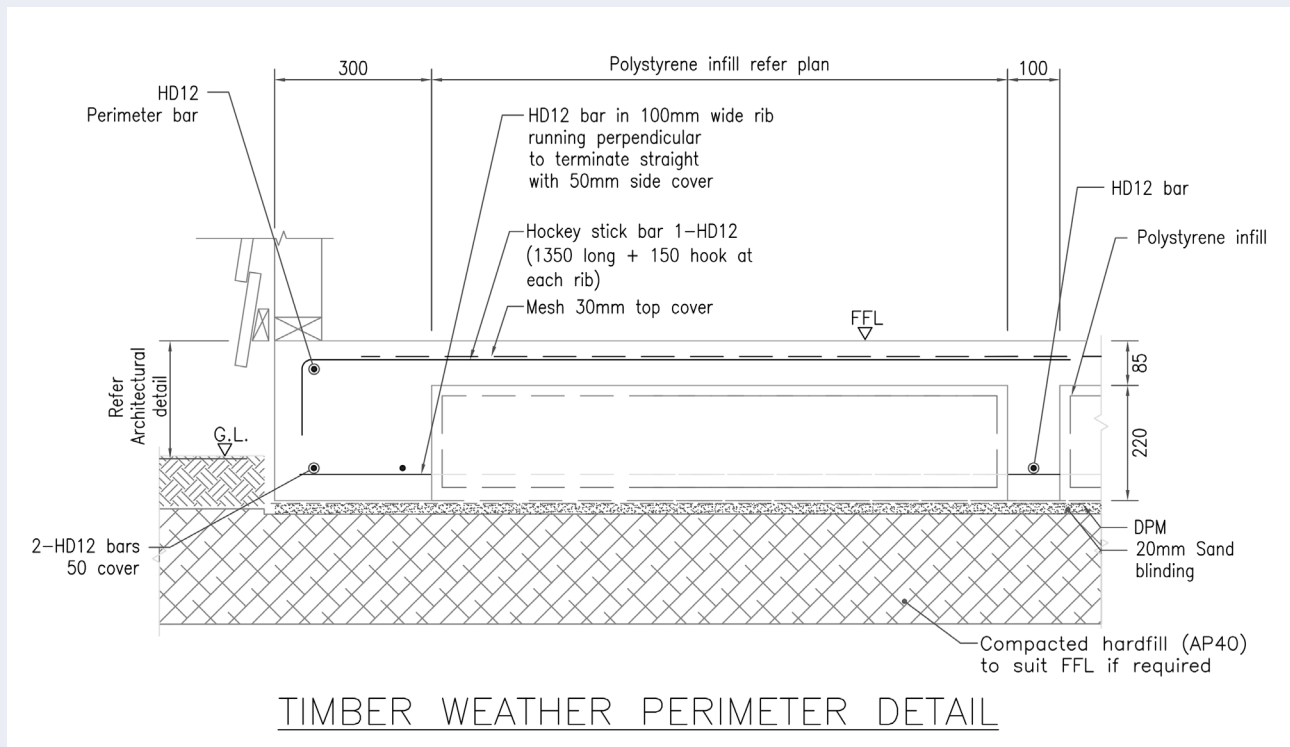

FIGURE 15 - Typical shower rebate details and corner bar lap detail



TIMBER WEATHER PERIMETER DETAIL

FIGURE 16 - Typical details - Lightweight cladding

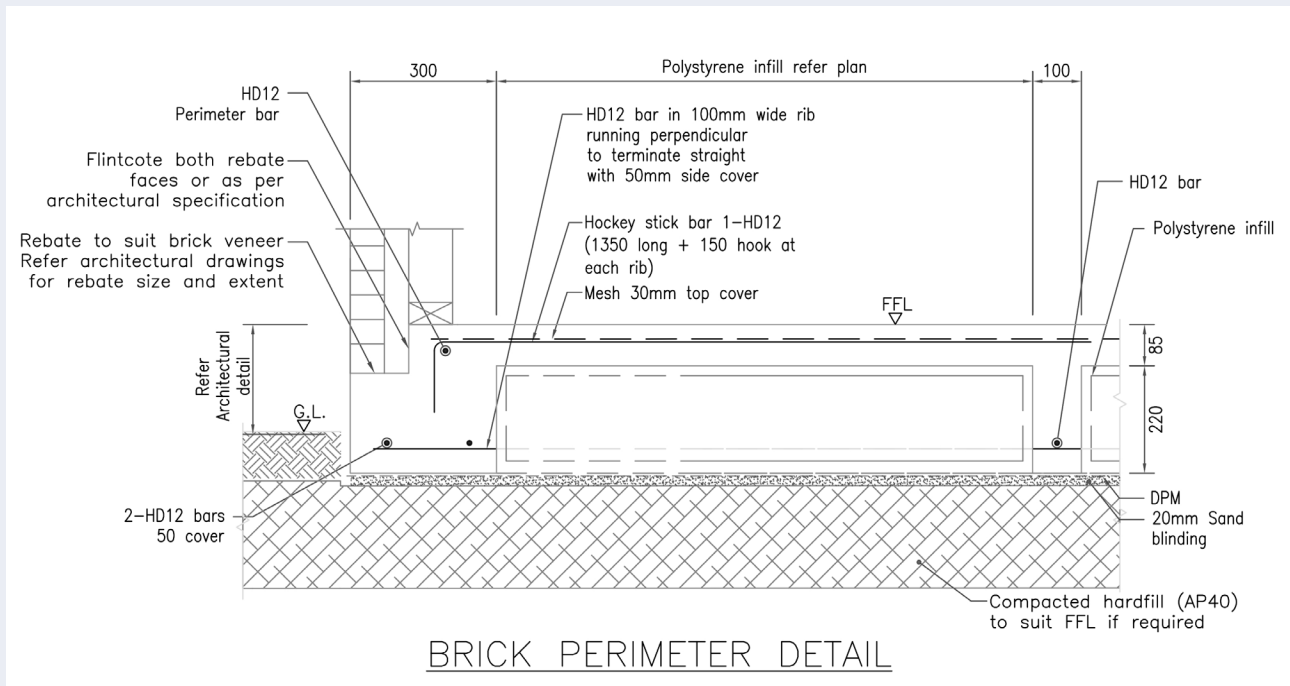

FIGURE 17 - Brick Rebate detail

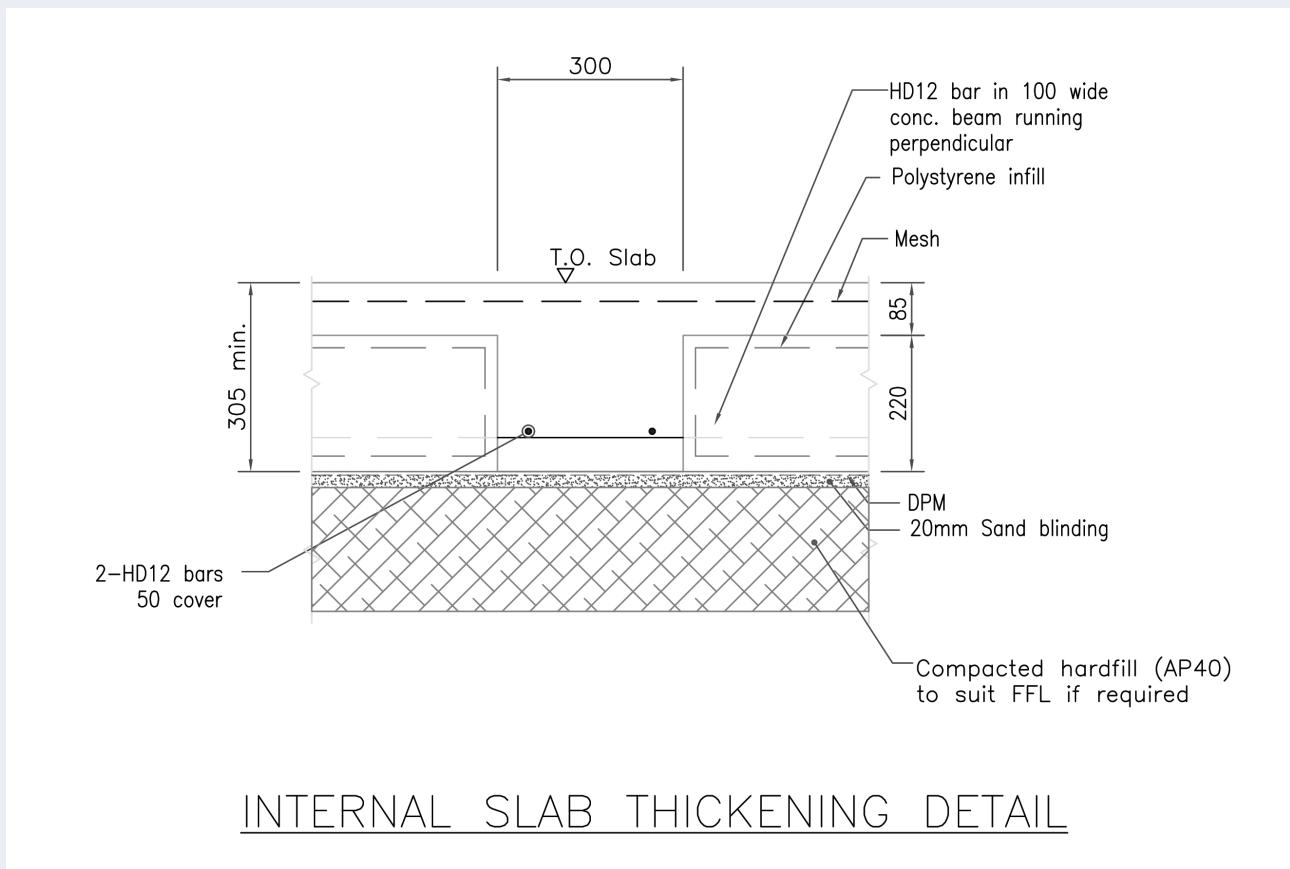

FIGURE 18 - Internal slab thickening

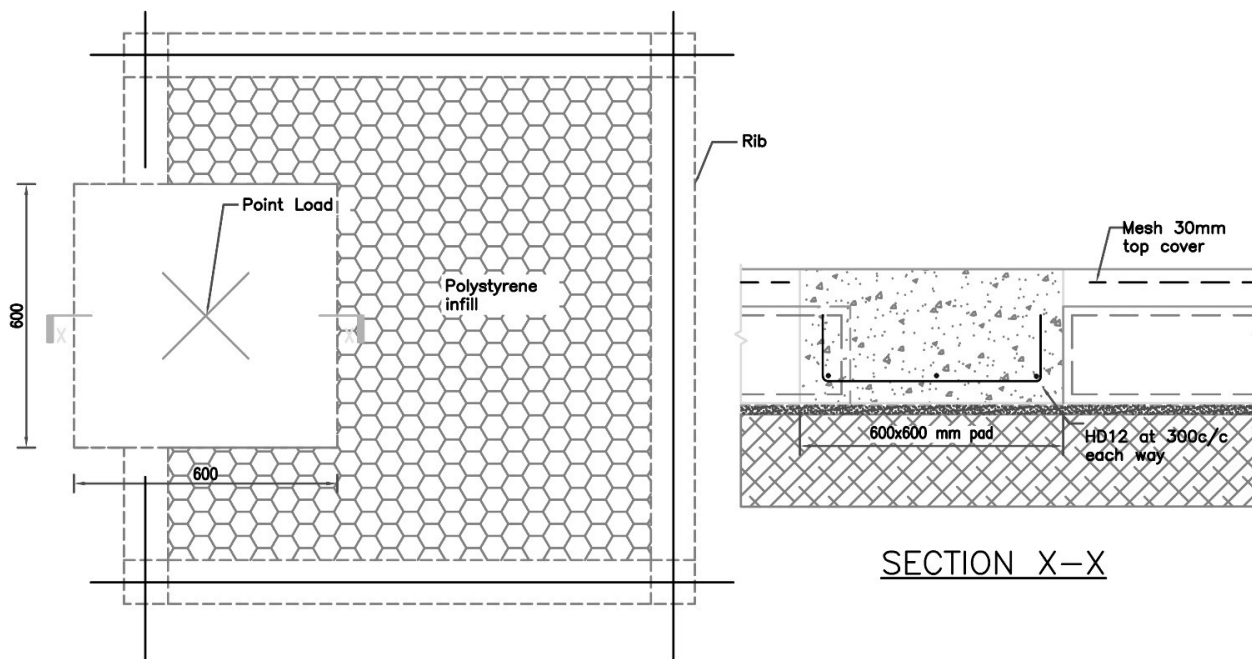
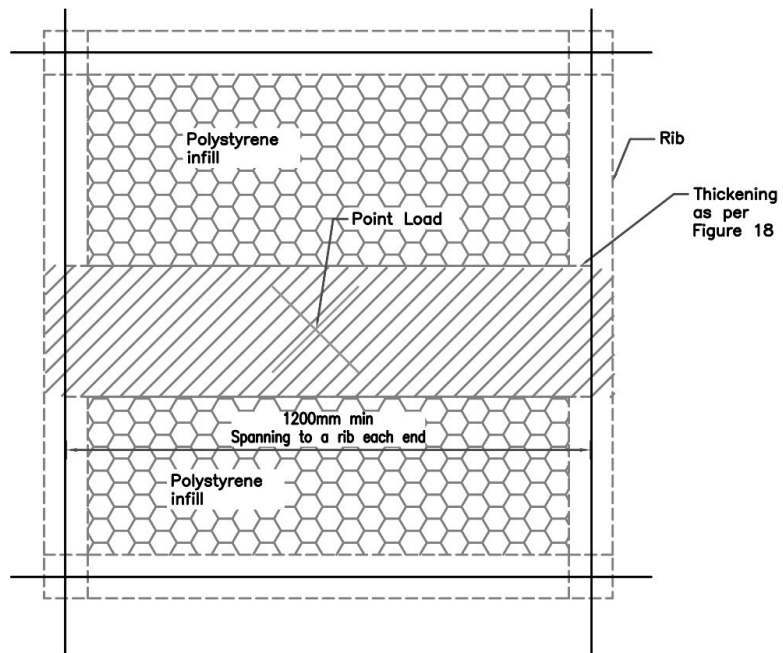

FIGURE 19 - Internal point loads larger than 13kN

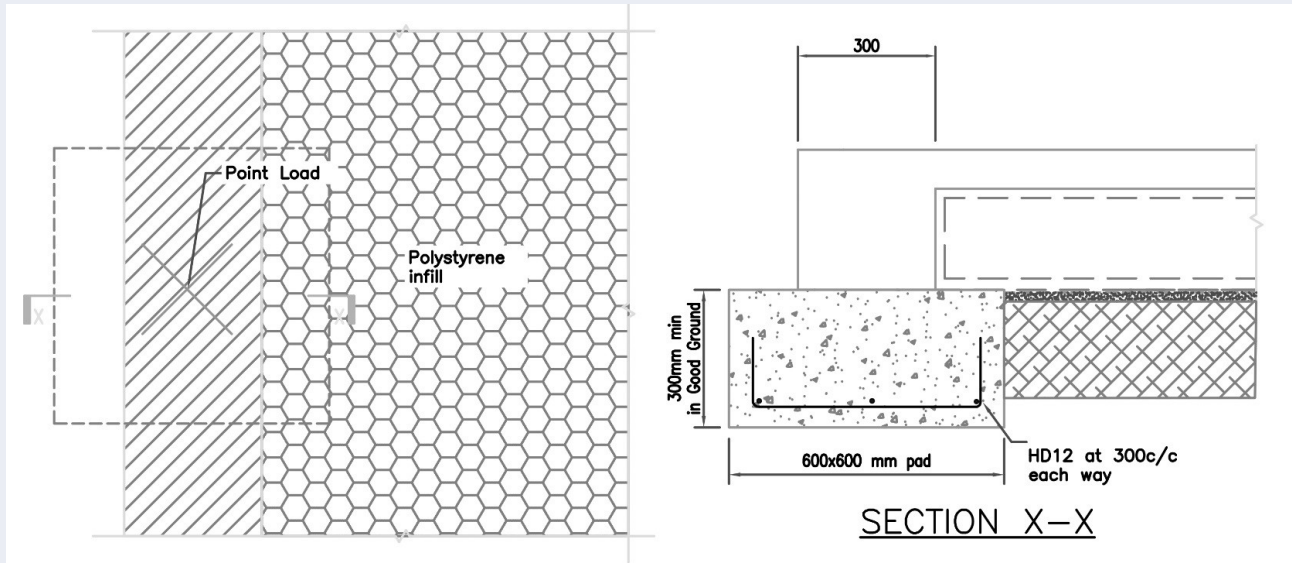

FIGURE 20 - Perimeter point loads larger 20kN

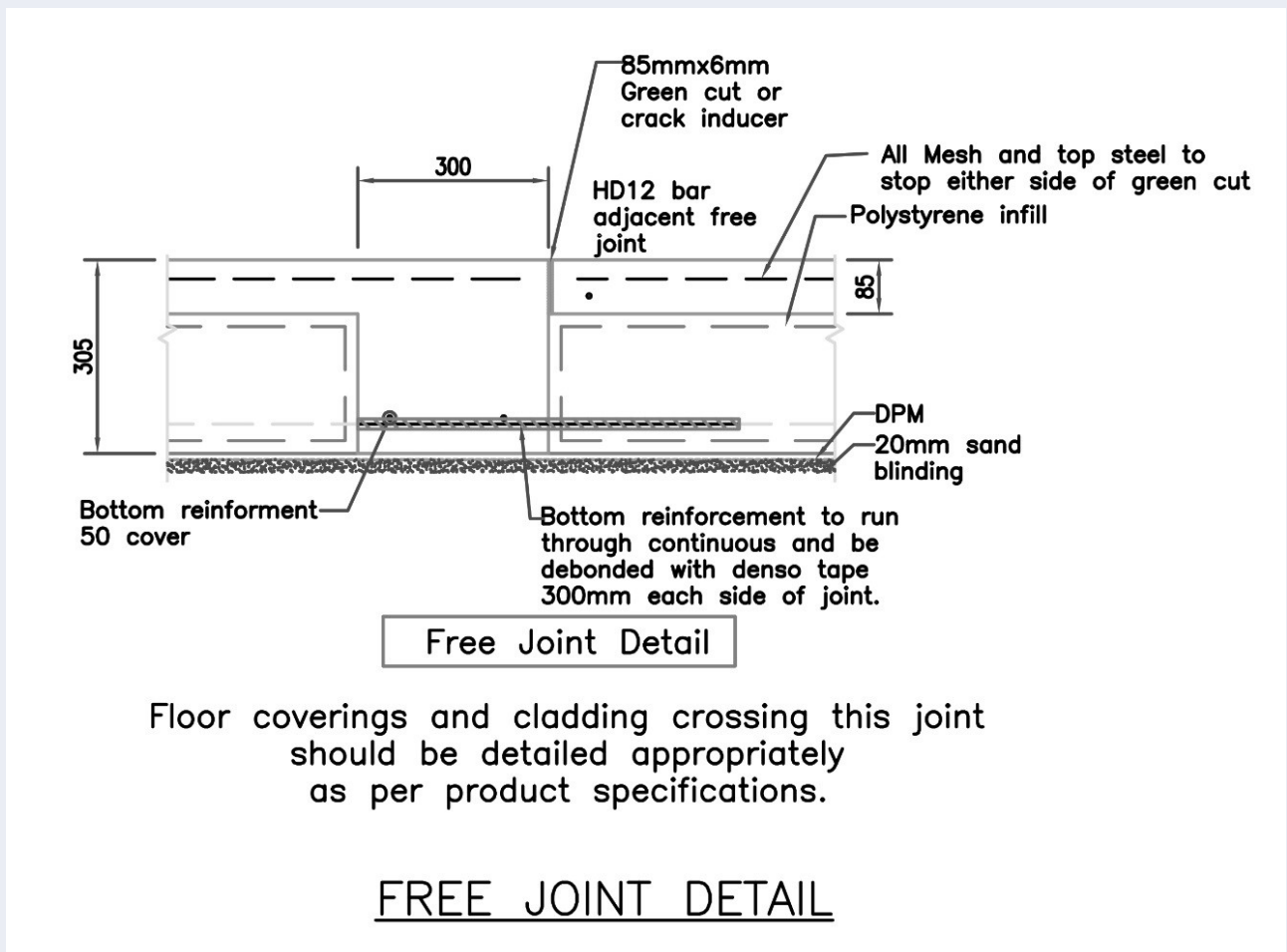

FIGURE 21 - Free Joint

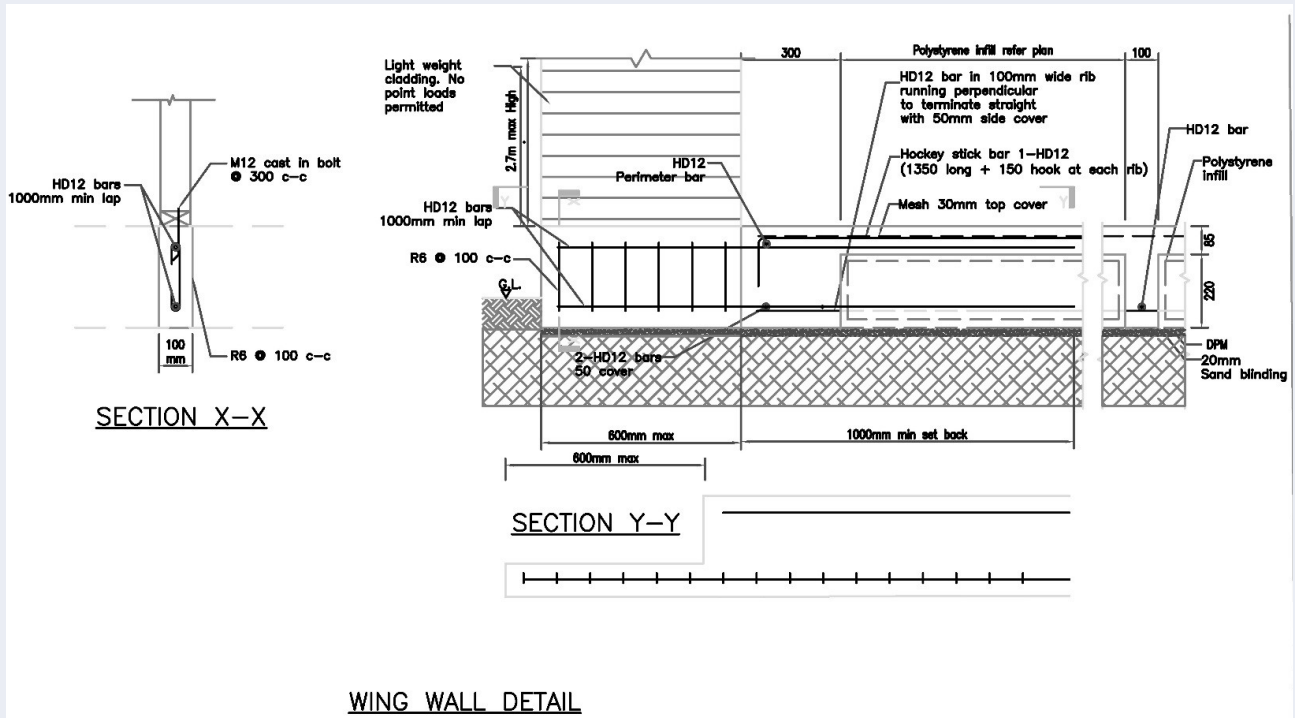

FIGURE 22 - Wingwall detail

6.1 Qpod substitutions detailing

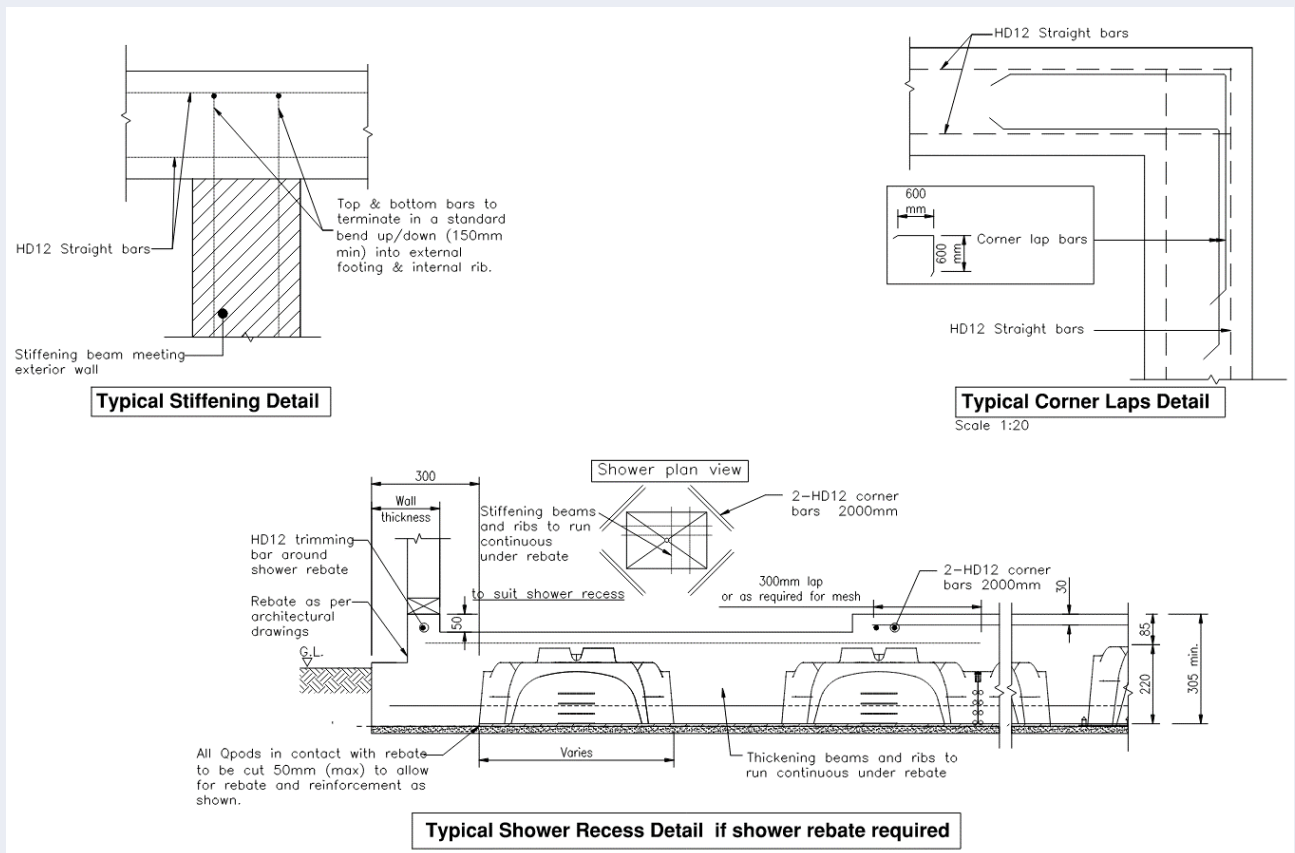

FIGURE 23 - Qpod rebate and corner details

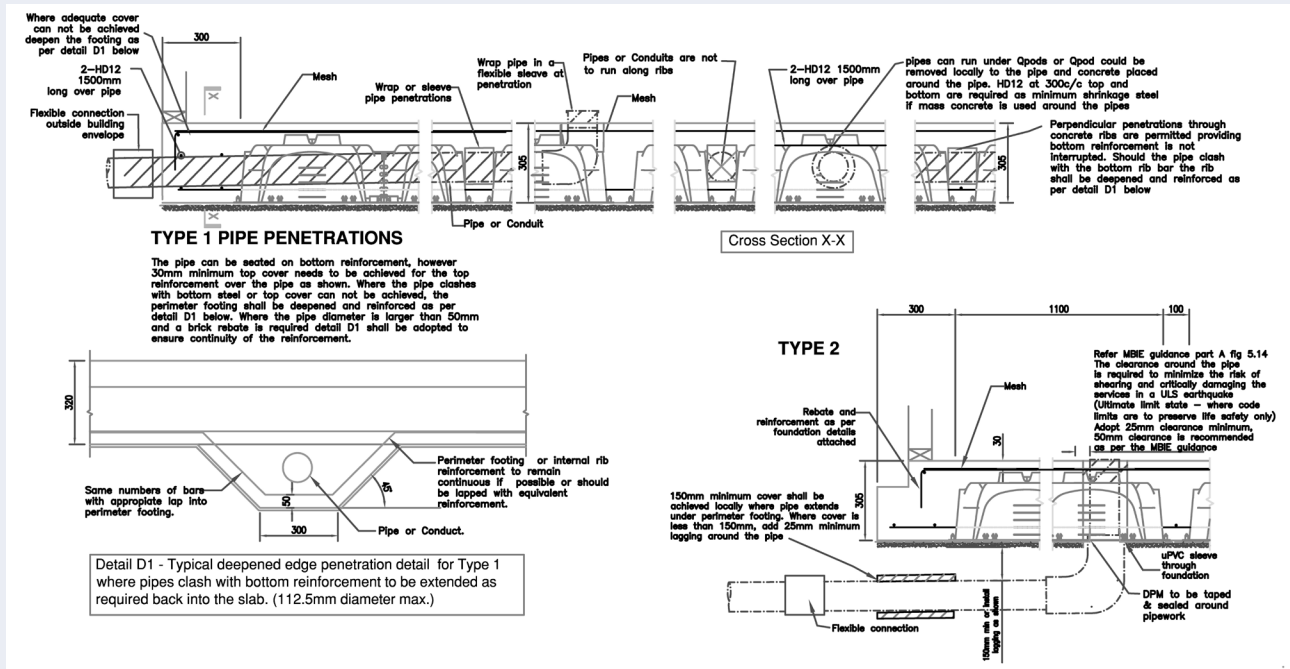

FIGURE 24 - Qpod pipe penetration details for high seismic zones. Refer to MBIE guideline section A figure S14 & S15 and building code clause G13

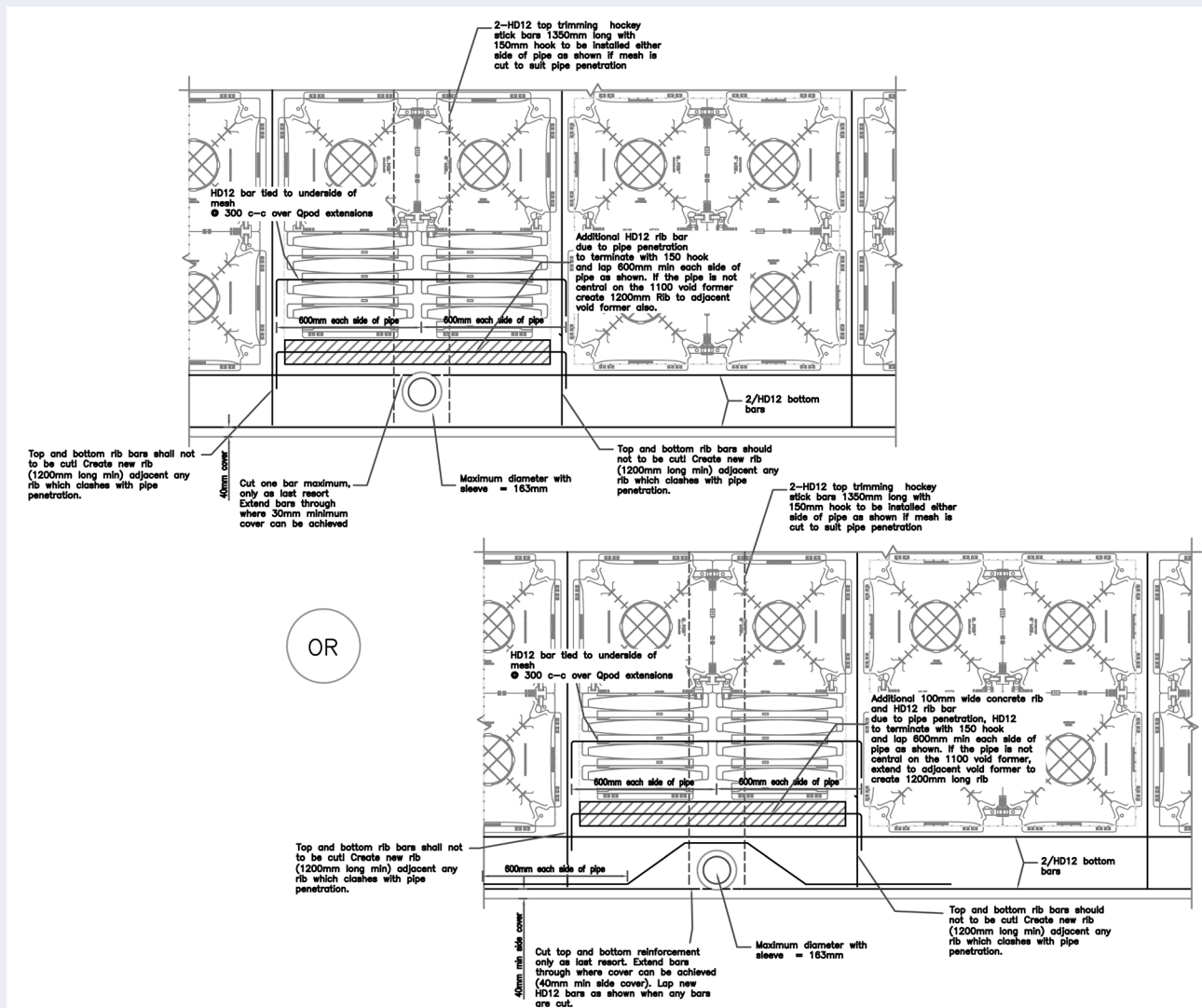

FIGURE 25 - Qpod perimeter footing pipe penetrations

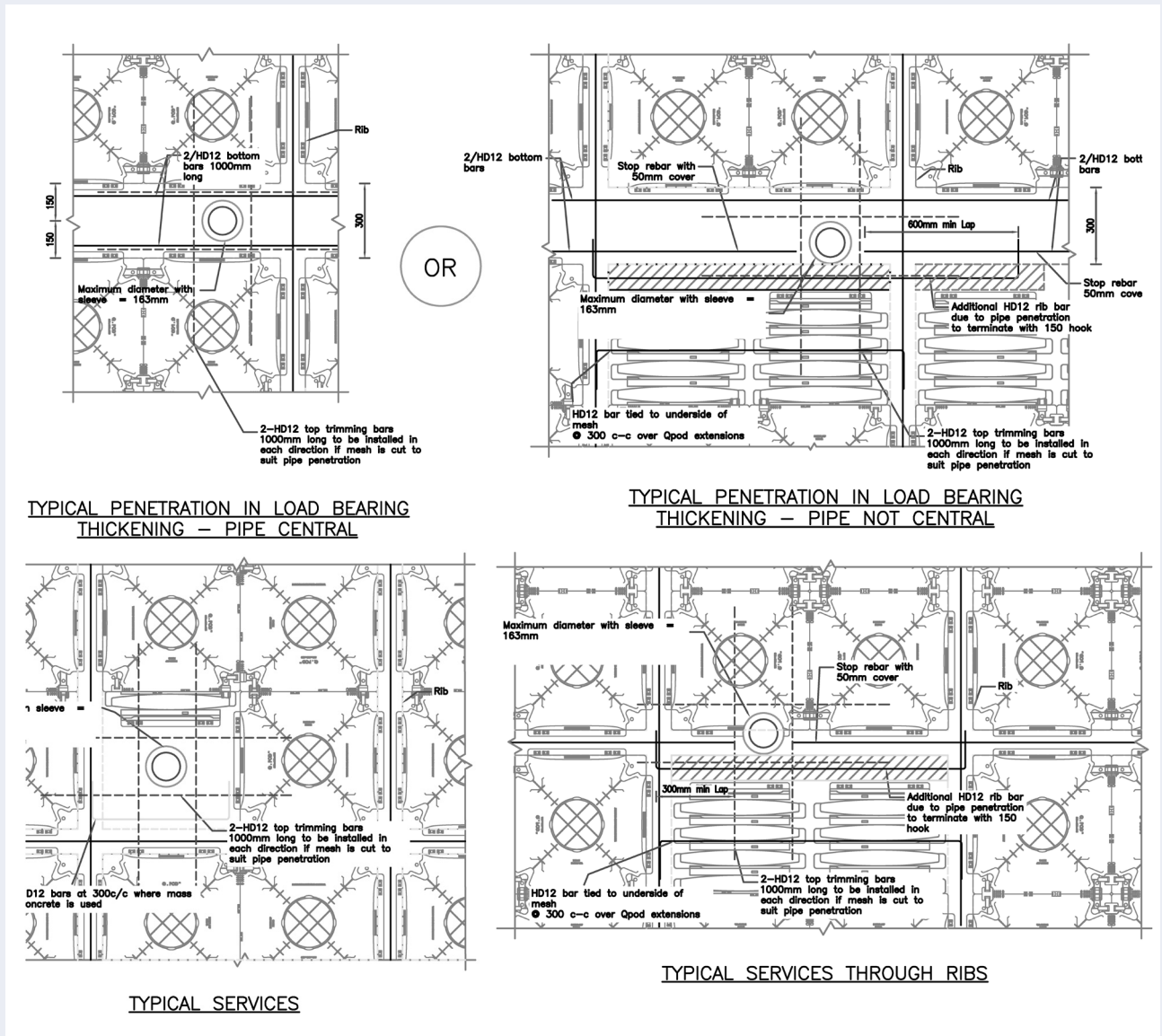

FIGURE 26 - Qpod internal pipe penetrations

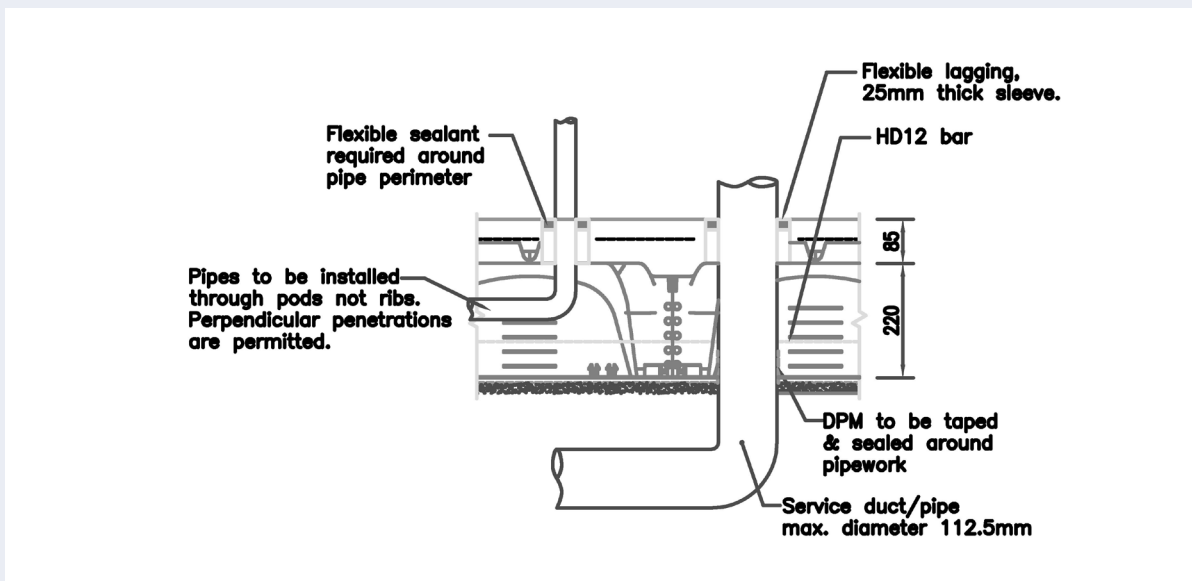

FIGURE 27 - Qpod vertical pipe penetrations

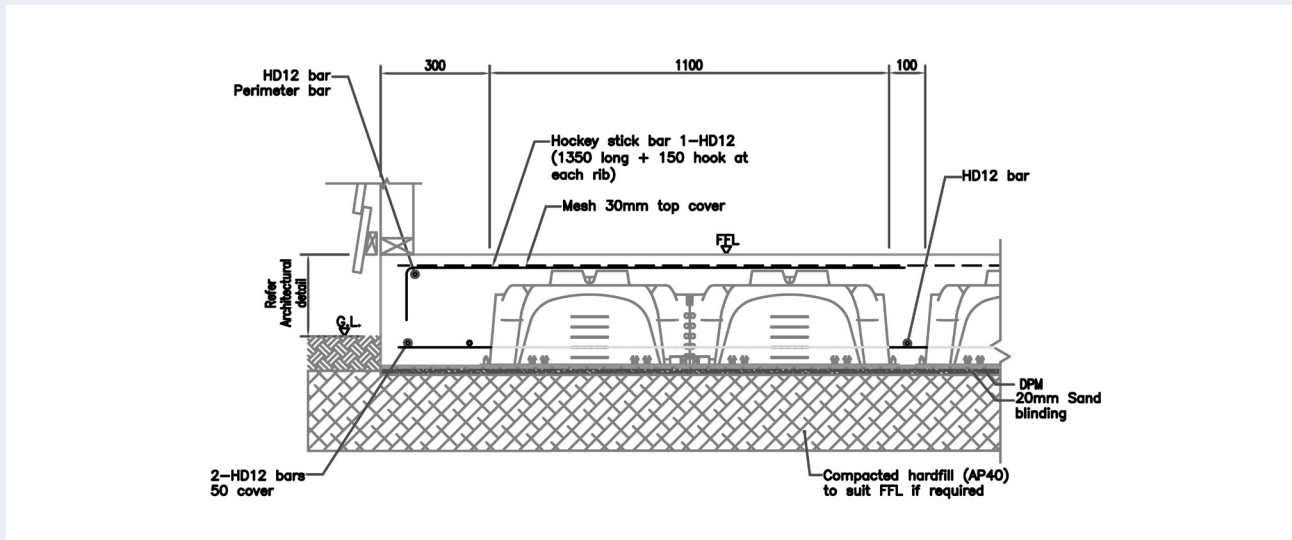

FIGURE 28 - Qpod light cladding perimeter detail

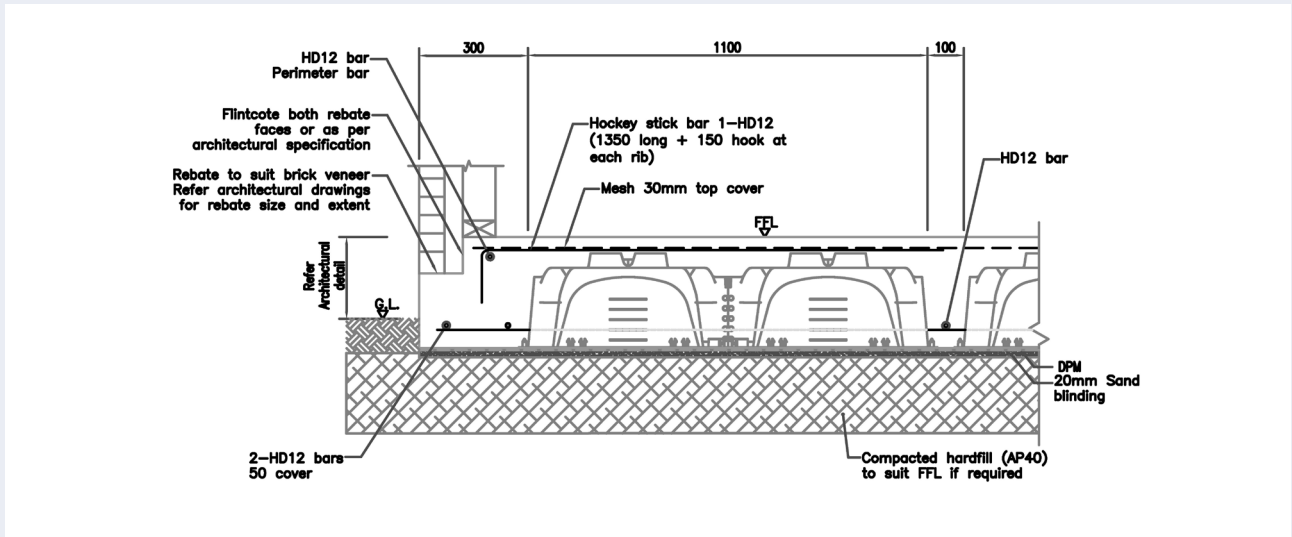

FIGURE 29 - Qpod brick cladding perimeter detail

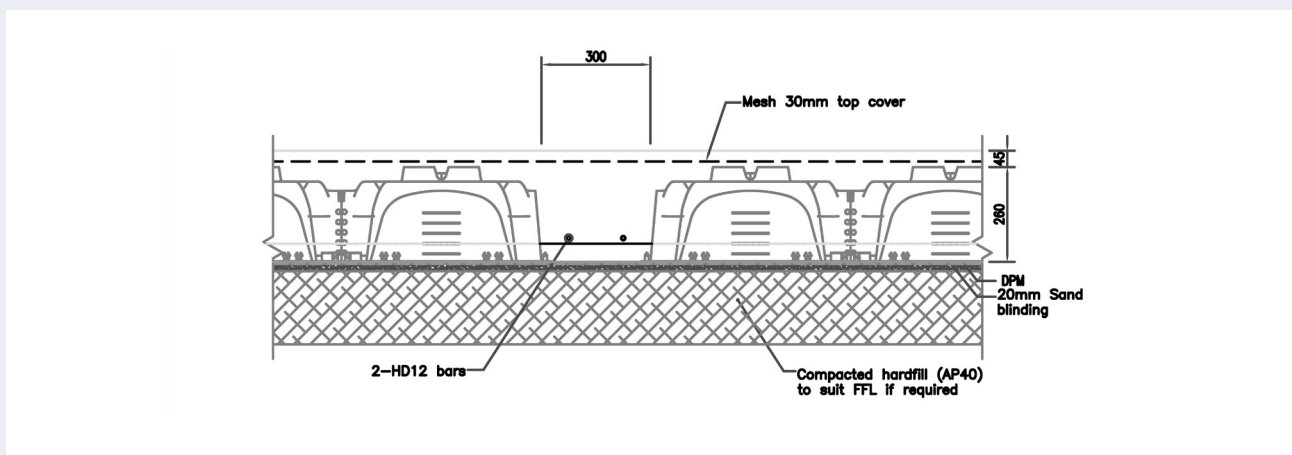

FIGURE 30 - Qpod internal loadbearing wall or slab thickening

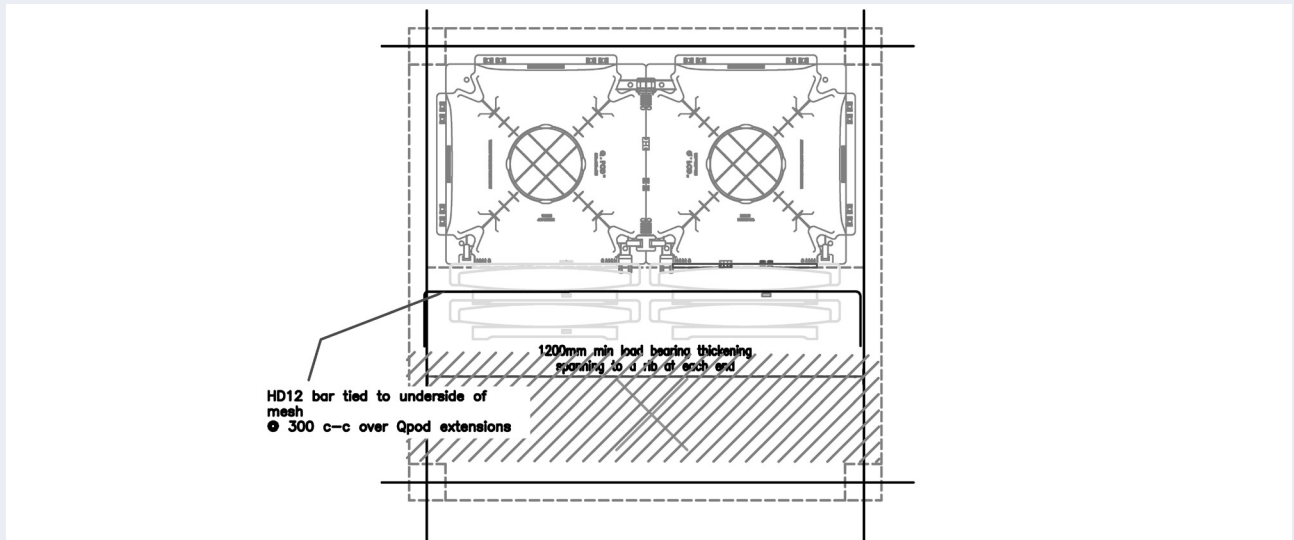

FIGURE 31 - Qpod internal point load - slab thickening

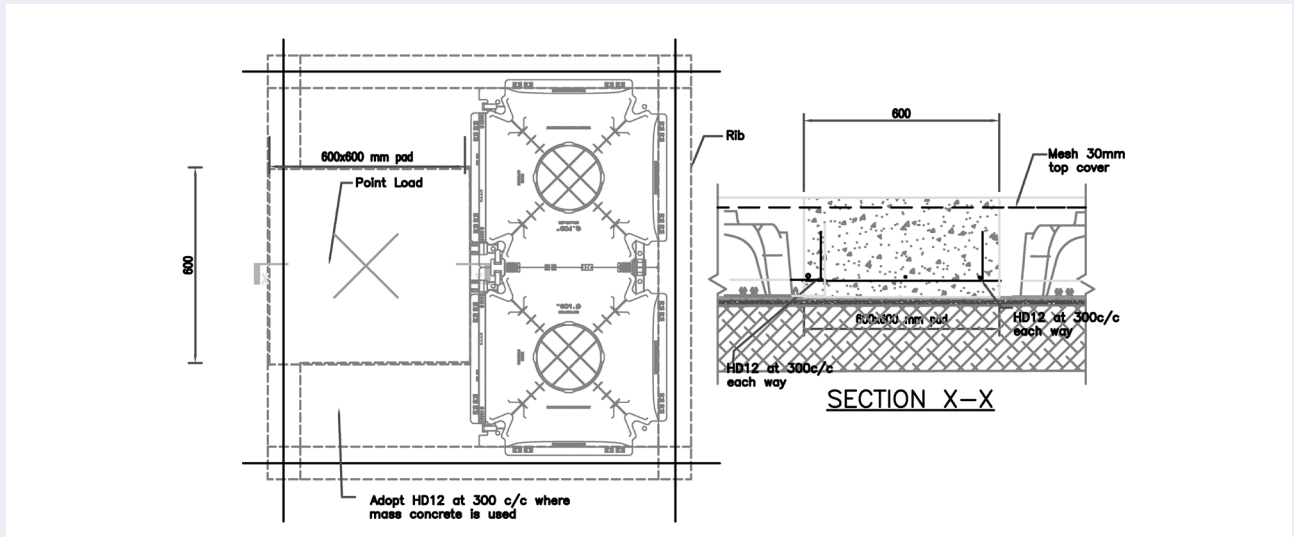

FIGURE 31b - Qpod internal point load - pad footing

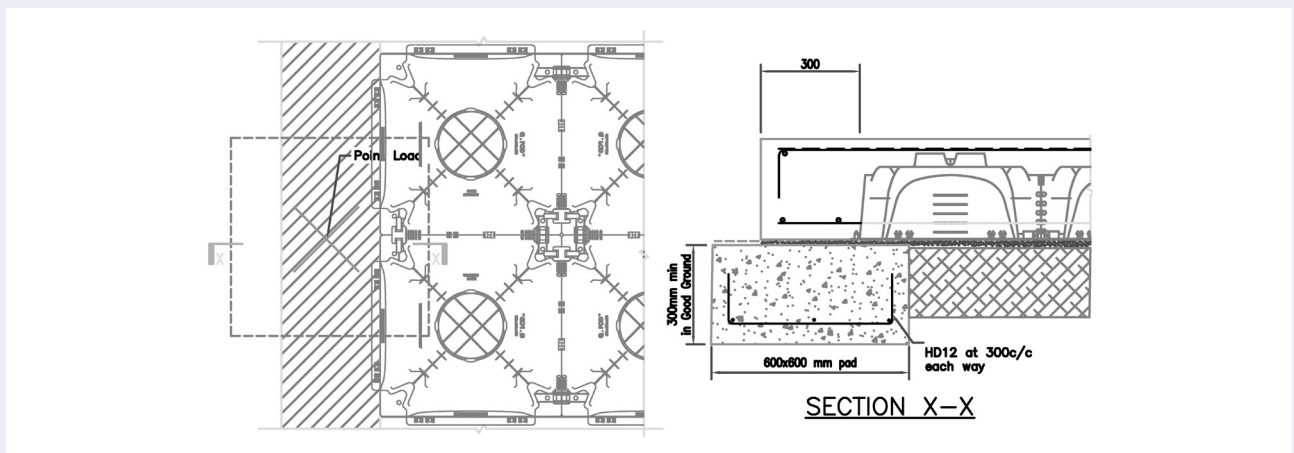
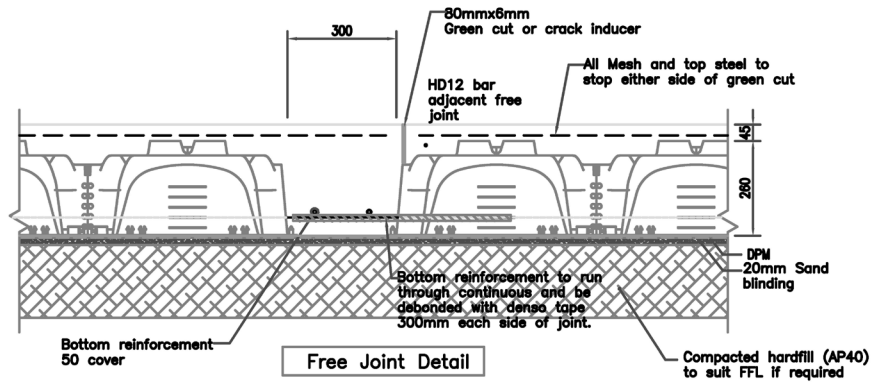

FIGURE 32 - Qpod perimeter point load - pad footing



Floor coverings and cladding crossing this joint should be detailed appropriately as per product specifications.

FREE JOINT DETAIL

FIGURE 33 - Qpod free joint detail

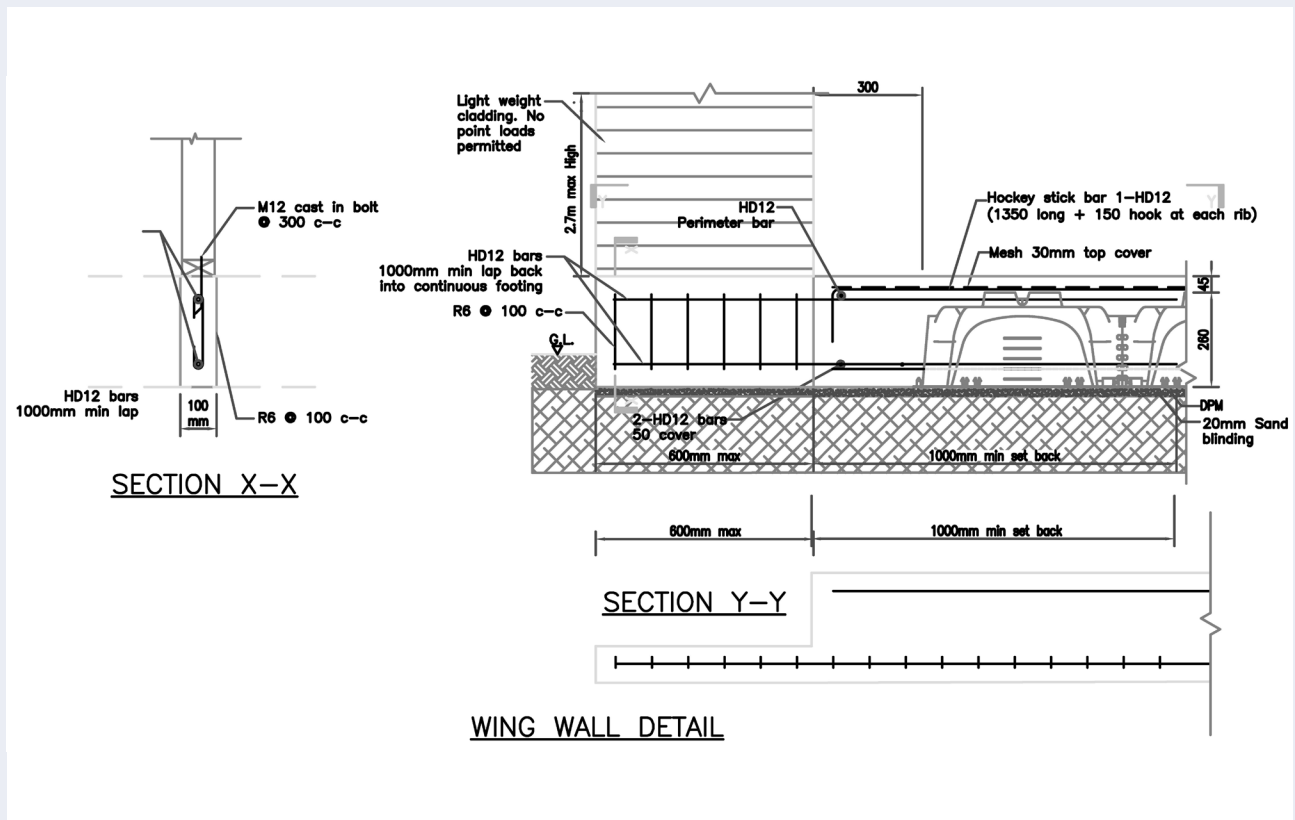

WING WALL DETAIL

FIGURE 34 - Qpod wingwall detail

7.0 - INSULATED SLABS

The R value required is dependent on the climate zone, whether there is in slab heating built into the foundations and the area to perimeter ratio. The designer shall verify the foundation R value compliance with H1/AS1&AS2.

The R-value is mainly dependent on the area to perimeter ratio of the foundation the edge of the foundation around the perimeter of the building is where most of the heat is lost. Insulating the exposed perimeter edge will achieve the best results relative to cost in comparison to underslab insulation. Underslab insulation (with and without edge insulation) can be used for SuperSlab providing the insulation is VH grade (or better) and a maximum thickness of 150mm (max). In colder climates edge and underslab insulation is likely to be required to achieve compliance with H1/AS1&AS2.

SuperSlab+ has been designed using the QuickSet and QuickEdge system, refer to tables 3 and 4 below for the building types compatible with SuperSlab+. The designer shall verify the R value of the foundation to ensure it meets the minimum NZBC requirements. Refer to www.QuickSet.co.nz or www.alliedconcrete.co.nz for further information on how to calculate the thermal performance of SuperSlab+.

7.1 SuperSlab+

The QuickSet perimeter edge form work or QuickEdge (16mm PVC foam board) is not considered to contribute to the vertical strength of the foundations. 100mm down from the slab surface, 20mm insulation is built into the edge formwork and can also be extended under the slab for a fully insulated slab. The insulation and boxing system creates an overhang, as a result edge loads are limited by the framing size and building cladding type as per the below.

SuperSlab+ can be used when complying with table 3 and 4 below for the selected wall framing (90mm/140mm) respectably. SuperSlab+ shall be installed as per the QuickSet manufacturers installation manual and details as per the below. The wall framing is permitted to overhang the foundations by a maximum of 6mm (measured from the boxing). Brick veneer shall not have any overhang. Hold downs anchors are to be installed with edge distances as indicate by the QuickSet detailing below and shall maintain a minimum edge distance of 56mm from the boxing (40mm from the concrete).

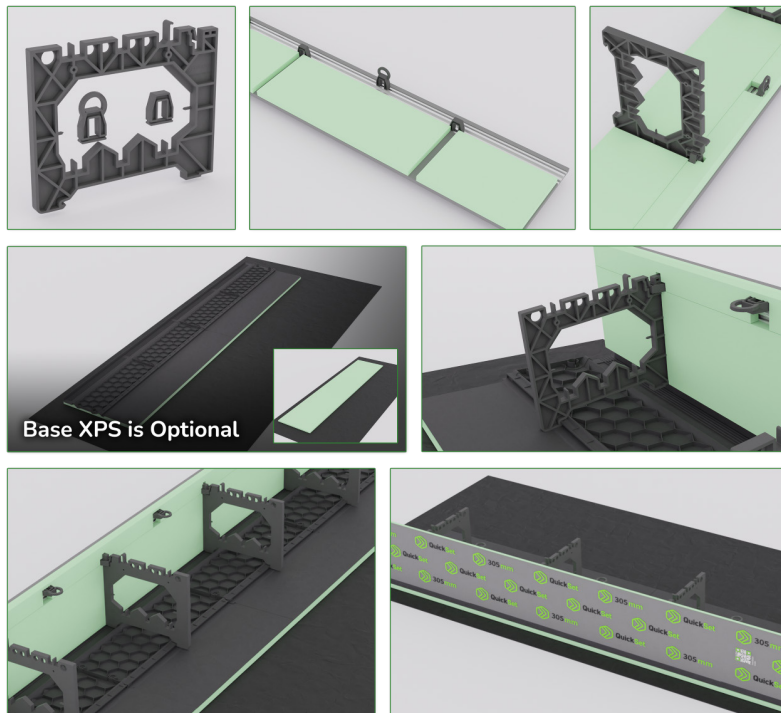

QuickSet

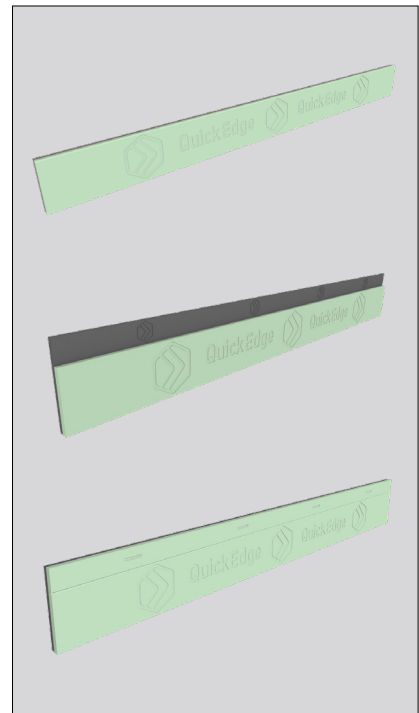

QuickEdge

90mm Wall Framing:

The SuperSlab+ system is suitable for perimeter loading for building types A, B and D as per table 1 of the SuperSlab Manual when 90mm wall framing is adopted.

Table 3

Building type	Number of levels ¹	Level 1 Wall cladding ²	Upper storey cladding	Roof Type ³	Minimum bearing capacities and penetrometer blows ⁴	Within scope of this document
A	Single	Light	–	Light	150 kPa	Yes
B	Single	Heavy	–	Light	200 kPa	Yes
C	Single	Heavy	–	Heavy	200 kPa	No, Specific Design
D	Two Storey	Light	Light	Light	200 kPa	Yes
E	Two Storey	Heavy	Light	Light	300 kPa	No, Specific Design
F	Two Storey	Heavy	Light	Heavy	300 kPa	No, Specific Design
G	Two Storey	Heavy	Heavy	Heavy	300 kPa	No, Specific Design

- *Refer section 3 for SuperSlab scope of use
- Point loads larger than 25kN will require specific design.

140mm Wall Framing:

Upgrading the wall framing to 140mm significantly increases the bearing capacity of the timber and edge distance available for the hold down bolts as such heavier building weights are permitted - Types A-E as per the below where 140mm framing is adopted.

Table 4

Building type	Number of levels ¹	Level 1 Wall cladding ²	Upper storey cladding	Roof Type ³	Minimum bearing capacities and penetrometer blows ⁴	Within scope of this document
A	Single	Light	–	Light	150 kPa	Yes
B	Single	Heavy	–	Light	200 kPa	Yes
C	Single	Heavy	–	Heavy	200 kPa	Yes
D	Two Storey	Light	Light	Light	200 kPa	Yes
E	Two Storey	Heavy	Light	Light	300 kPa	Yes
F	Two Storey	Heavy	Light	Heavy	300 kPa	No, Specific Design
G	Two Storey	Heavy	Heavy	Heavy	300 kPa	No, Specific Design

- *Refer section 3 for SuperSlab scope of use
- Point loads larger than 25kN will require specific design.

Hold down fixings

The hold fixings adopted need to meet proprietary requirements as defined by NZS3604 (7.5.12.3 refer below) and the BRANZ technical paper P21 (15kN characteristic uplift) for wall bracing elements where needed. Should specific wall bracing products require higher uplift capacities that foundation is beyond the scope of this document and shall require specific design.

7.5.12.3

For *external walls*, proprietary anchors shall have a minimum *capacity* when tested in accordance with 2.4.7 as follows:

- (a) Horizontal *loads* in the plane of the *wall* 2kN;
- (b) Horizontal *loads* out of the plane of the *wall* 3kN;
- (c) Vertical *loads* in axial tension of the fastener 7kN.

Hilti have carried out verification of the hold downs to meet the NZS3604 loading requirements.

Standard bottom plate fixing: HILTI screw anchor – HUS3-H 10mm diameter (130mm long), 85mm min embedment @ 800c/c – installed as per manufacturers specifications.

15kN brace wall: HILTI chemical anchor – HIT-RE 500 V4 + HAS 8.8HDG M10 (190mm long), 110mm minimum embedment – installed as per manufacturers specifications.

Alternatively to the above, proprietary hold downs can be used, where the product accounts for the edge insulation and minimum edge distances required. These proprietary products shall demonstrate compliance with NZS 3604 and building code requirements (as outlined above).

7.2 QuickSet and QuickEdge Standard detailing

SuperSlab+ can be specified with QuickSet and QuickEdge as edge insulation alone or combined with base insulation for a fully insulated foundation. Refer to the QuickSet and QuickEdge detailing library for system detailing requirements.

